

IF IN DOUBT ASK

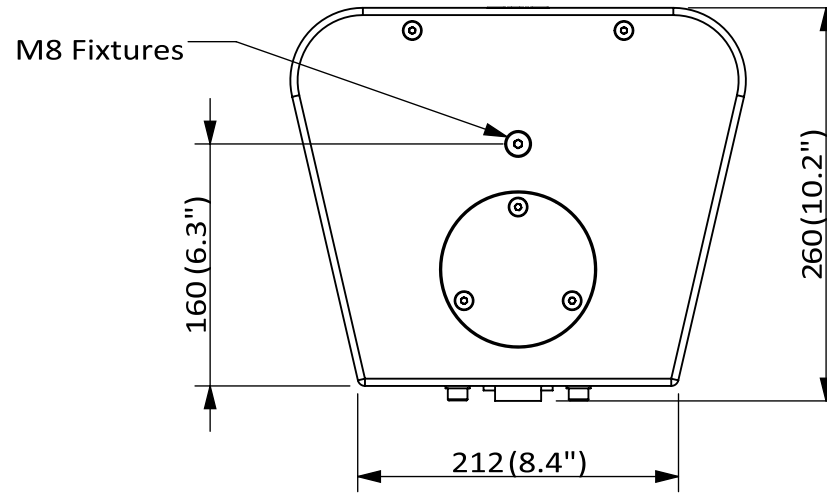
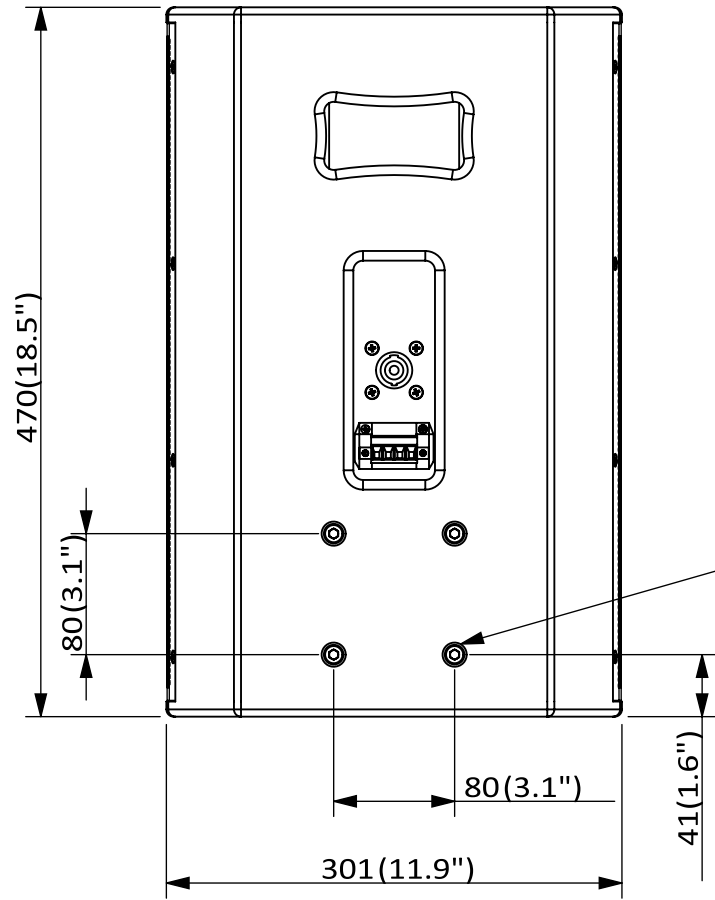
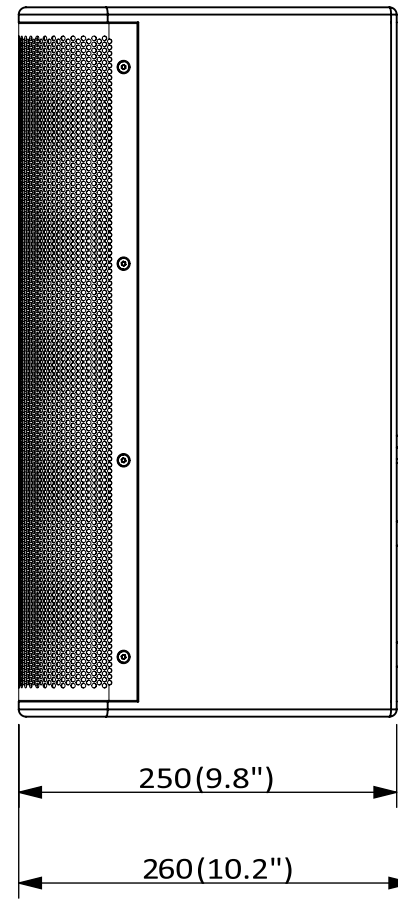
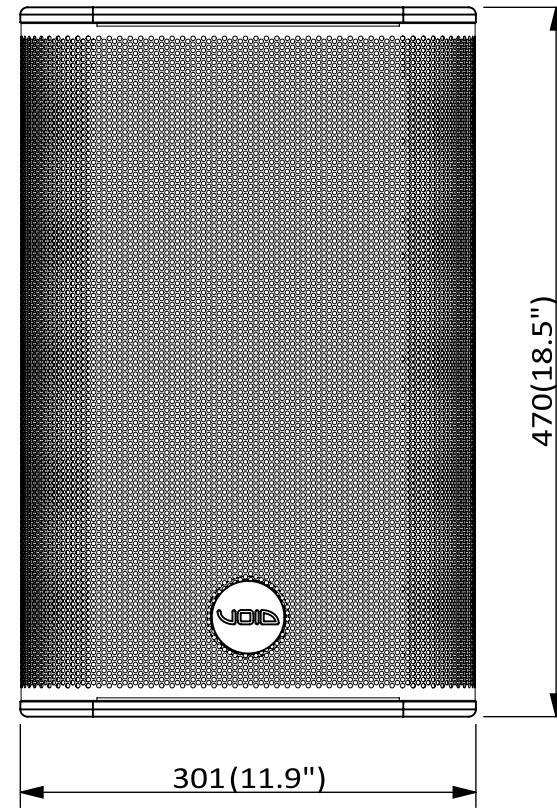
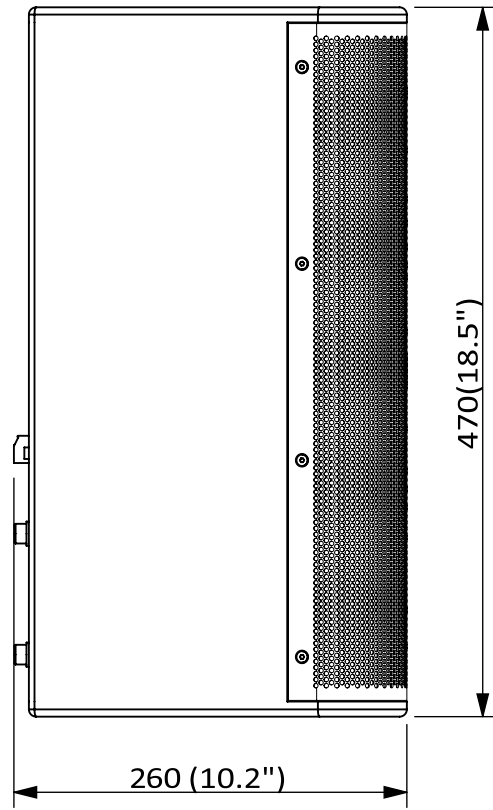
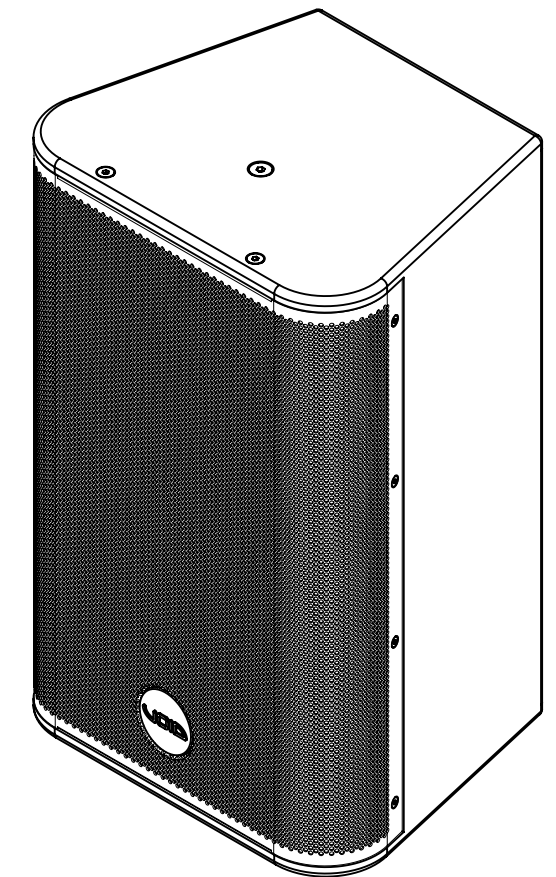
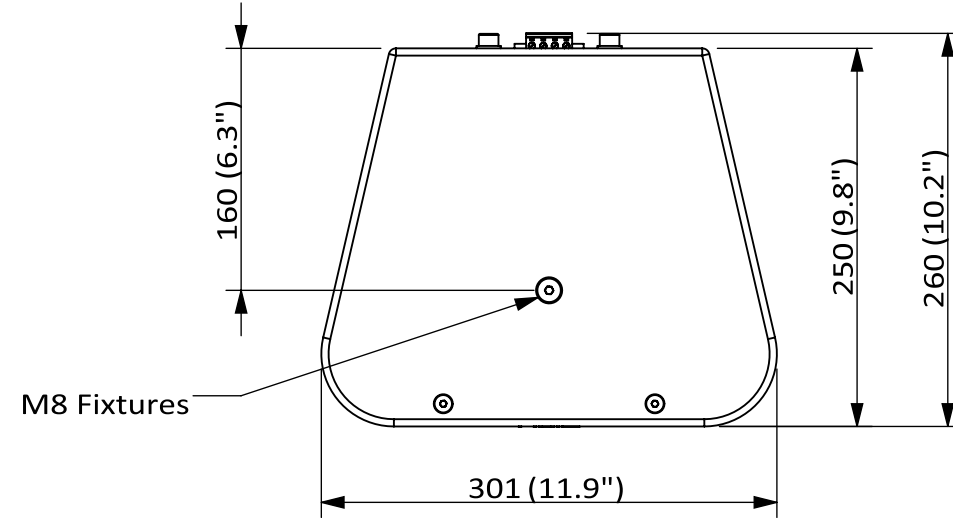

M8 Fixtures (4 POS)

	NAME	DATE	DIMENSIONS IN MILLIMETRES				
			FABRICATION UNLESS OTHERWISE STATED		MACHINING UNLESS OTHERWISE STATED		
DRAWN	SHEN	18/03/2019	UP TO 500mm	+/-0.5mm	0, mm	+/- 0.5 mm	BREAK EDGE
CHECKED			500mm - 1m	+/-1.0mm	0.0 mm	+/- 0.2 mm	0.05 - 0.15mm
APPROVED			1m - 5m	+/-2.0mm	0.00mm	+/- 0.1mm	FILLET RADII
			5m - 10m	+/-5.0mm	0.000mm	+/- 0.01mm	0.1 - 0.3mm
			ANGULAR	±1°	ANGULAR	±0.5°	

SURFACE TEXTURE VALUES IN MICROMETRES (µm) TO BS1134-PT2. ALL MACHINED SURFACES TO BE ✓. ALL SCREW THREADS TO BS3643 PT.2.

TITLE: OVERALL DIMENSIONS		DRAWING No. SP10067-001	
PROJECT: VENU 10 V2		SAP No. IT2094	REV. 1
MATERIAL: AS ABOVE	GUAGE: (mm)	EST. WEIGHT: (Kg) 16	
FINISH:	COLOUR: BLACK	TEXTURE:	
THIRD ANGLE PROJECTION TO BS 8888	SCALE: 1:5	SHT 1 OF 1 SHTS	SHEET: A3



REPRODUCTION OF ANY PART OF THIS DOCUMENT IS FORBIDDEN WITHOUT PRIOR PERMISSION FROM VOID ACOUSTICS.  
DESIGN COPYRIGHT RESERVED.  
CONFIDENTIAL AND PROPRIETARY INFORMATION OF VOID ACOUSTICS.