



Hear. Feel. Connect.

voidacoustics.com



Inca 500

Pro audio you can depend on

USER GUIDE V1.0

©2023 Void Acoustics Research Ltd.

This user guide is subject to change without notice.
For the latest online version, visit: www.voidacoustics.com

Void Acoustics and the Void logo are registered trademarks of Void Acoustics Research Ltd. in the United Kingdom, USA and other countries; all other Void trademarks are the property of Void Acoustics Research Ltd.

Contents

1	Safety and Regulations	4	6	Connections	22
1.1	Important Safety Instructions	4	6.1	Main Power Connection	22
1.2	Limitations	4	6.2	Input Connection	22
1.3	EC Declaration of Conformity	4	6.3	Output Connections	22
1.4	UKCA Conformity	4	6.4	Speaker Cable Gauge	23
1.5	Warranty Statement	4	6.5	GPIO Connections	24
1.6	WEEE Directive	4	6.6	Network Connections	24
2	Unpacking and Checking	6	7	Operations	26
3	About	7	7.1	Front Panel Indicators	26
3.1	Welcome	7	7.2	Automatic Power Sharing	27
3.2	Inca 500 Overview	7	7.3	Default Reset	27
3.3	Key Features	7	8	Specifications	28
3.4	Connections	8			
3.5	Network Features	8			
3.6	Dimensions	8			
4	Installation	9			
4.1	Inca 500 Mounting	9			
4.2	Free Standing	10			
5	Configurations	11			
5.1	Mains Power Connection	11			
5.2	Network Services	11			
5.2.1	Wired (Ethernet) Network Connections	11			
5.2.2	Wireless (WiFi) Network Connection	12			
5.3	Configuration Menus	13			
5.3.1	Input Tab	13			
5.3.2	Zone Tab	14			
5.3.3	Output Tab	15			
5.3.4	Speaker Preset Menu Parameters	17			
5.3.5	Settings Tab	18			
5.4	Setup and Signal Routing	18			
5.4.1	Input Setup	19			
5.4.2	Zone Setup & Routing	19			
5.5	GPIO Setup and Connection	21			

1 Safety and Regulations

1.1 Important safety instructions



The lightning flash with an arrowhead symbol within an equilateral triangle is intended to alert the user to the presence of uninsulated "dangerous voltage" within the product's enclosure that may be of sufficient magnitude to constitute a risk of electric shock to persons.



The exclamation point within an equilateral triangle is intended to alert the user of the presence of important operating and maintenance (servicing) instructions in the literature accompanying the appliance.

Safety instructions - read this first

1. Read these instructions.
2. Keep these instructions.
3. Heed all warnings.
4. Follow all instructions.
5. Do not use this apparatus near water.
6. Do not submerge the equipment in water or liquids.
7. Do not use any aerosol spray, cleaner, disinfectant or fumigant on, near or into the equipment.
8. Clean only with a dry cloth.
9. Do not block any ventilation opening. Install in accordance with the manufacturer's instructions.
10. Do not install near any heat sources such as radiators, heat registers, stoves, or other apparatus (including amplifiers) that produce heat.
11. To reduce the risk of electrical shock, the power cord shall be connected to a mains socket outlet with a protective earthing connection.
12. Do not defeat the safety purpose of the polarized or grounding type plug. A polarized plug has two blades with one wider than the other. A grounding type plug has two blades and a third grounding prong. The wide blade or the third prong are provided for your safety. If the provided plug does not fit into your outlet, consult an electrician for replacement of the obsolete outlet.
13. Protect the power cord from being walked on or pinched particularly at plugs, convenience receptacles, and the point where they exit from the apparatus.
14. Do not unplug the unit by pulling on the cord, use the plug.
15. Only use attachments/accessories specified by the manufacturer.
16. Unplug this apparatus during lightning storms or when unused for long periods of time.
17. Refer all servicing to qualified service personnel. Servicing is required when the apparatus has been damaged in any way, such as power supply cord or plug is damaged, liquid has been spilled or objects have fallen into the apparatus, the apparatus has been exposed to rain or moisture, does not operate normally, or has been dropped.
18. The appliance coupler, or the AC Mains plug, is the AC mains disconnect device and shall remain readily accessible after installation.
19. Adhere to all applicable, local codes.
20. Consult a licensed, professional engineer when any doubt or questions arise regarding a physical equipment installation.

1.2 Limitations

This guide is provided to help familiarise the user with the loudspeaker system and its accessories. It is not intended to provide comprehensive electrical, fire, mechanical and noise training and is not a substitute for industry-approved training. Nor does this guide absolve the user of their obligation to comply with all relevant safety legislation and codes of practice. While every care has been taken in creating this guide, safety is user-dependent and Void Acoustics Research Ltd cannot guarantee complete safety whenever the system is rigged and operated.

1.3 EC declaration of conformity

For EC Declaration of Conformity please go to:

www.voidacoustics.com/eu-declaration-amplifiers

1.4 UKCA marking

For details of the UKCA marking go to:

www.voidacoustics.com/uk-declaration-amplifiers

1.5 Warranty statement

For warranty statement go to:

<https://voidacoustics.com/terms-conditions/>



1.6 WEEE directive

If the time arises to throw away your product, please recycle all the components possible.

This symbol indicates that when the end-user wishes to discard this product, it must be sent to separate collection facilities for recovery and recycling. By separating this product

from other household-type waste, the volume of waste sent to incinerators or land-fills will be reduced and natural resources will thus be conserved.

The Waste Electrical and Electronic Equipment Directive (WEEE Directive) aims to minimise the impact of electrical and electronic goods on the environment. Void Acoustics Research Ltd complies with the Directive 2002/96/EC and 2003/108/EC of the European Parliament on waste electrical and electronic equipment (WEEE) in order to reduce the amount of WEEE that is being disposed of in land-fill sites. All of our products are marked with the WEEE symbol; this indicates that this product must NOT be disposed of with other waste. Instead it is the user's responsibility to dispose of their waste electrical and electronic equipment by handing it over to an approved reprocessor, or by returning it to Void Acoustics Research Ltd for reprocessing. For more information about where you can send your waste equipment for recycling, please contact Void Acoustics Research Ltd or one of your local distributors.

Please read the following important technical, safety and environmental notices before installing and using your amplifier.

Technical Notices

All reasonable design and engineering steps have been taken to ensure that these amplifiers always perform satisfactorily in their intended application and environment and will provide appropriate levels of support to ensure that all reasonable customer needs and expectations are met. Such support however is contingent on the following provisions.

1. These amplifiers are Class-I products and should be installed with a mains cable including the required earth connection to comply with the Safety Class-I.
2. These amplifiers should always be installed by competent and qualified personnel. Amplifier damage or failure caused by installation or operational errors may invalidate support, warranty or guarantees of performance.
3. These amplifiers are not suitable for use in locations where they may be accessible to minors.
4. These amplifiers are intended to be used specifically for the amplification of audio signals and for connection to moving-coil loudspeaker systems. Use of these amplifiers for amplification of signals outside the audio band (20Hz to 20kHz) or to drive transducers other than moving-coil loudspeakers may invalidate support, warranty or guarantees of performance.
5. These amplifiers should only be used within professionally installed and configured audio systems comprising input and output ancillary equipments that is known to be of an appropriate level of performance and in good operating condition. Any damage to, or unsatisfactory performance from, these amplifiers caused by inadequate or failed input or output ancillaries may invalidate support, warranty or guarantees of performance.
6. These amplifiers are intended to be installed and operated indoor in a controlled environment (pollution degree, PD2) within an ambient temperature range of 0°C to 40°C. These amplifiers are not intended for use above 2000 meters above sea level. Amplifiers installation or operated in environments outside these limits may invalidate support, warranty or guarantees of performance.

Safety and Environmental Notices

WARNING! TO PREVENT FIRE OR ELECTRIC SHOCK, DO NOT EXPOSE THIS EQUIPMENT TO RAIN OR MOISTURE.



Ambient Temperature Note: If this equipment is operated in a confined or multiple rack installation, the internal ambient operating temperature may exceed the external ambient temperature. It is important to ensure in these circumstances that the published maximum operating temperature for the equipment is not exceeded.



Reduced Air Flow: Ensure that rack or other closed installation does not restrict the cooling airflow required for safe and reliable operation of the equipment.

2 Unpacking and Checking

All Void Acoustics products are carefully manufactured and thoroughly tested before being despatched. Your dealer will ensure that your Void products are in pristine condition before being forwarded to you but mistakes and accidents can happen.

Before signing for your delivery:

- Inspect your shipment for any signs of contamination, abuse or transit damage as soon as you receive it
- Check your Void Acoustics delivery fully against your order
- If your shipment is incomplete or any of its contents are found to be damaged; inform the shipping company and inform your dealer.

Carton Contents

Inca 500 amplifiers are shipped in a cardboard carton containing the amplifier unit, a mains cable appropriate for the sales territory, an accessory pack, and a document pack. The full contents is listed below.

- Amplifier unit
- Mains power cable
- Input connector x 2
- GPIO socket connector
- Output connector x 2
- Adhesive rubber feet x 4
- Document pack

3 About

3.1 Welcome

Many thanks for purchasing this Void Acoustics Inca Series amplifier. We truly appreciate your support. At Void, we design, manufacture and distribute advanced professional audio systems for the installed and live sound market sectors. Like all Void products, our highly skilled and experienced engineers have successfully combined pioneering technologies with ground-breaking design aesthetics, to bring you superior sound quality and visual innovation. In buying this product, you are now part of the Void family and we hope using it brings you years of satisfaction. This guide will help you both use this product safely and ensure it performs to its full capability.

3.2 Inca 500 overview

The Inca 500 amplifier is a half rack width, 1U format power amplifier that can drive both conventional low impedance (Low-Z, 4Ω to 16Ω) loudspeakers and high impedance (Hi-Z, 70V/100V) transformer coupled loudspeakers. The Inca 500 provides four analog inputs, one stereo S/PDIF digital input, and four outputs (Low-Z mode) or two outputs (Hi-Z mode). It is capable of a maximum output of 125 Watts per channel into Low-Z loads or 250 Watts per channel into Hi-Z loads. The Inca 500 also incorporates automatic power sharing technology that enables 250 Watts to be shared proportionately as required across each output pair in Low-Z mode and the two outputs in Hi-Z mode.

3.3 Key features

- Full matrix DSP embedded and controlled via TCP/IP
- Master / Slave functionality – S/PDIF link to multiple amps
- Market proven reliability
- Automatic power sharing
- Small size with flexible mounting

3 About

3.4 Connections

Inca 500 signal input and output connections are accomplished via RCA Phono and Euroblock style connectors. A GPIO (General Purpose In/Out) Euroblock connector enables some amplifier functions to be controlled, and wireless or RJ45 socket Ethernet network connection options are also provided.

Inca 500 amplifiers have no mains power switch and are operational as soon as mains power is connected via the IEC 60320 mains socket.

3.5 Network Features

Inca 500 amplifiers are TCP/IP network connected devices that require a wired or wireless network connection to access their configuration menus. The configuration menus are accessed via a web page interface and cover Input, Zone, Output and General Settings functions. The configuration menus are fully described in Section 5 of this manual.

3.6 Dimensions

Inca 500 amplifier dimensions and features are illustrated in figure 3.1. The amplifiers are primarily intended for installation in an equipment rack but can also be under-desk or wall mounted, or used free standing. They are fan-cooled and must be installed such that ventilation apertures are not obstructed.

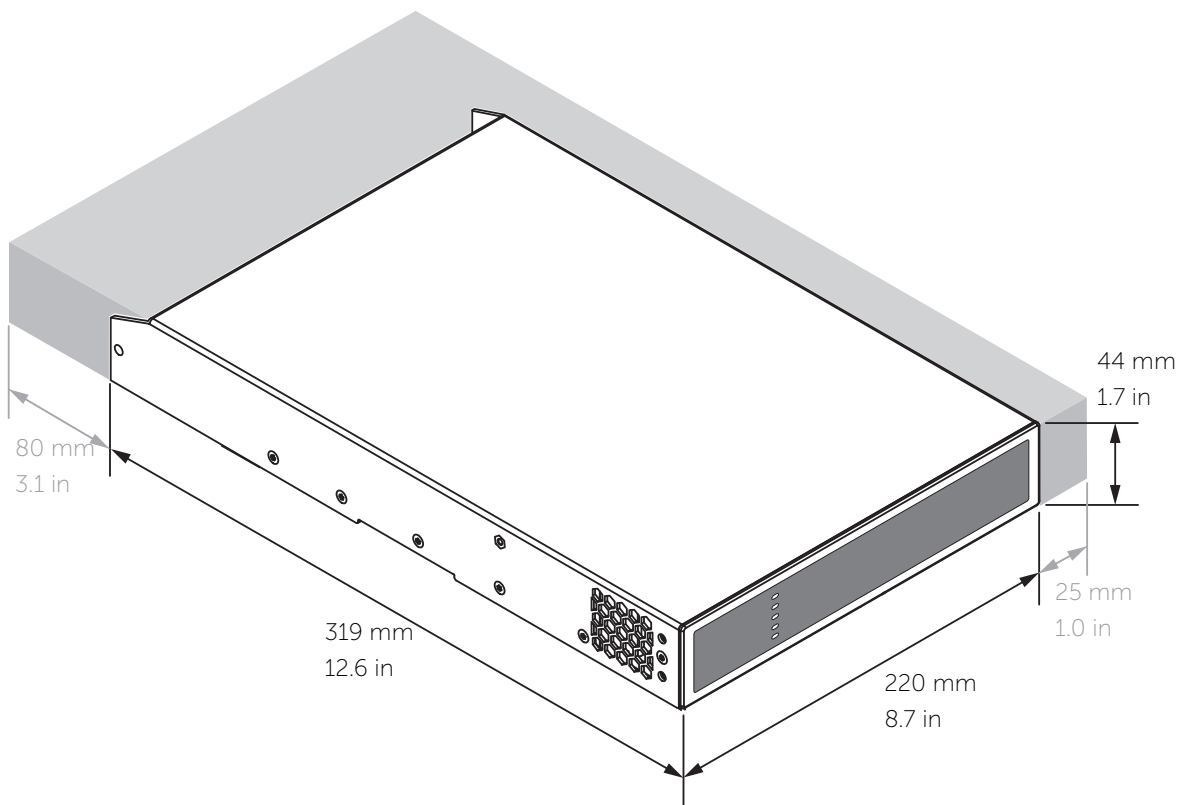

Figure 3.1: Inca 500 four channel amplifier dimensions. Shaded area defines ventilation space.

4 Installation

Note: The rack mounting and desk/wall mounting components described and illustrated in Sections 4.1 to 4.3 are not supplied with Inca 500 amplifiers but are available to purchase as accessories. Contact sales@voidacoustics.com for more information.

4.1 Inca 500 Mounting

The Inca 500 amplifiers are shipped without rack mount hardware attached but can be configured for rack installation using one standard rack 'ear' and one half-rack extension piece as illustrated in figure 4.1. The installation and equipment rack should be configured to provide appropriate ventilation airflow space around the sides and rear of the amplifier as illustrated in as illustrated in figure 3.1. Ventilation airflow space of at least 25 mm (1 in) should be maintained along at least one side of the amplifier at all times. Ventilation apertures are also located on the rear panel of the amplifier and must not be obstructed. It is important to retain at least 80 mm (3.1 in) free space for airflow behind the amplifier rear panel.

In addition to rack mount ears, optional rack mount rear support hardware is available and can be attached to the amplifier. Rear support hardware may be appropriate if the amplifier is to be used in a mobile rack or potentially be subject to significant movement. Figure 4.2 illustrates the use of rack mount rear support hardware.

Multiple Inca 500 amplifiers can also be mechanically connected using accessory connecting plates. Figure 4.3 illustrates the use of connecting plates.

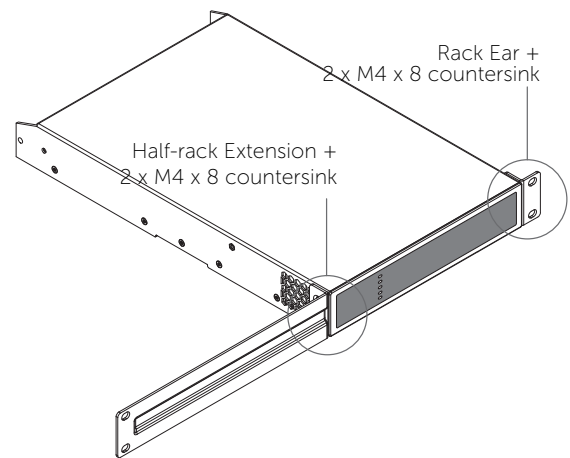

Figure 4.1: Inca 500 Rack Ear + Half-rack Extension.

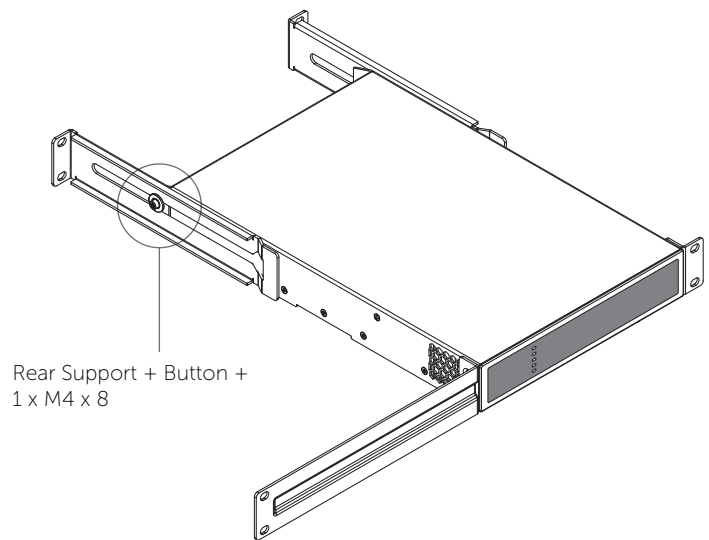

Figure 4.2: Inca 500 Rack Support hardware. 2 positions.

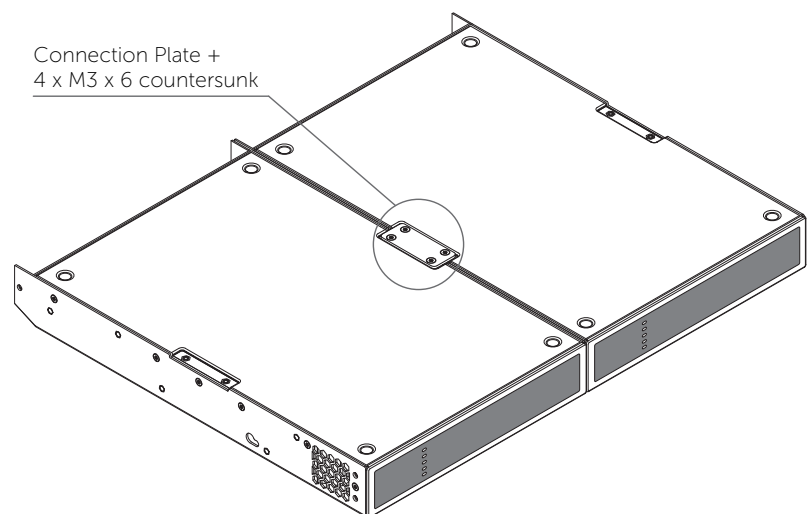

Figure 4.3: 2 x Inca 500 with Connection Plate. 2 positions

4 Installation

4.2 Free-standing

If not installed in an equipment rack, Inca 500 amplifiers can be placed free-standing on a flat surface. Adhesive rubber feet are supplied for this purpose.

Inca 500 amplifiers can also be attached to the underside of desks or wall mounted using connecting plate hardware. The adhesive rubber feet should also be used in these circumstances to minimise the possibility of vibration between the amplifier and mounting surface. Wall and desk mounting is illustrated in figure 4.4 and 4.5.

It is important in any free standing installation that airflow through the amplifier's side panel mounted fans and rear panel ventilation apertures is not compromised by adjacent items. At least 80mm of free space behind the amplifier and 25mm along at least one side should be retained at all times.

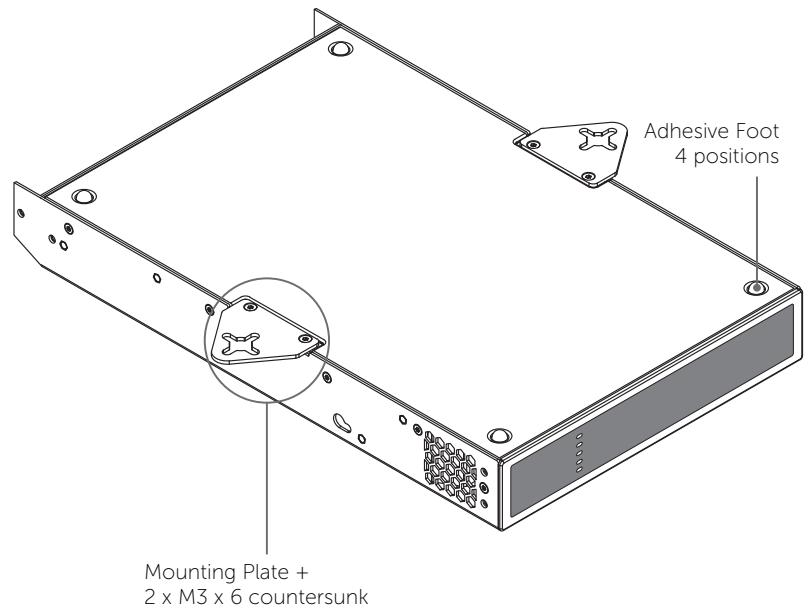

Figure 4.4: Inca 500 with desk/wall Mounting Plate and adhesive feet. 2 positions and 4 positions.

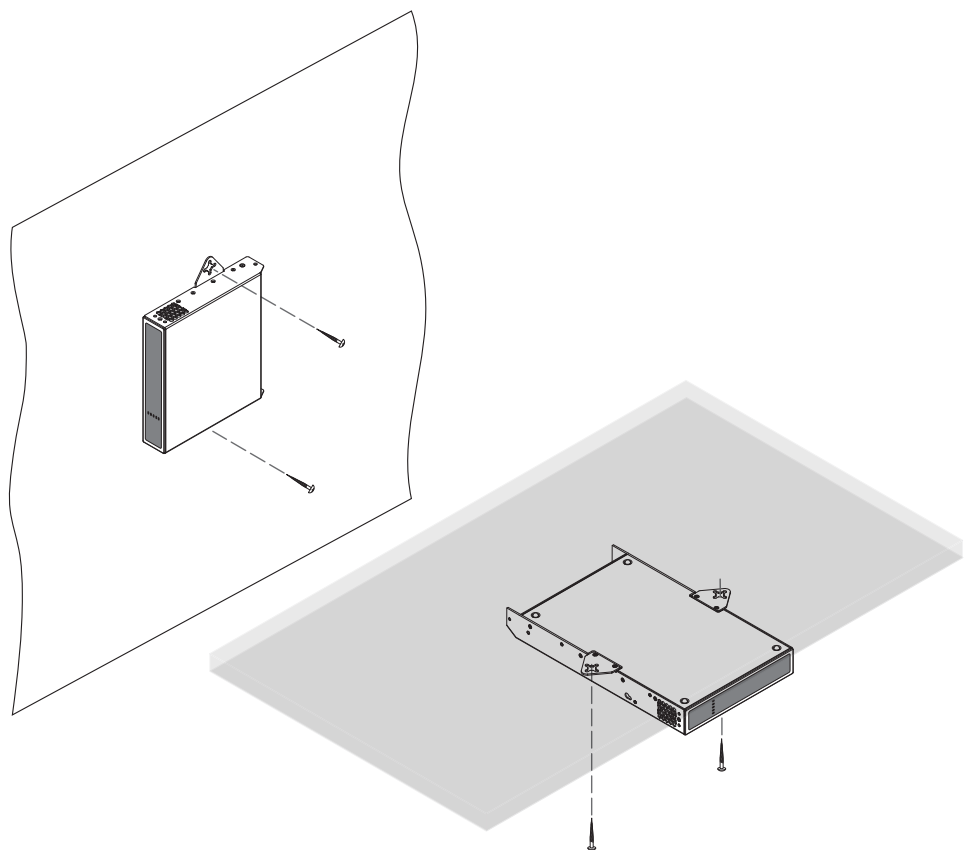

Figure 4.5: Inca 500 wall and under-desk mount.

5 Configurations

Before making input, output and GPIO connections, an initial Inca 500 amplifier configuration should be established. It is particularly important that the amplifier output format is configured appropriately for the speakers that are to be connected.

Configuration requires that Inca 500 amplifiers are connected to mains power and network services. These connections are described in the following two sections.

5.1 Mains Power Connection

Inca 500 amplifiers incorporate a power factor corrected power supply and can be used with mains input voltage from 100V AC to 240V AC, 50/60Hz. Use the mains cable supplied with the amplifier and connect it to a switched mains supply.

Inca 500 amplifiers have no mains power switch and are operational as soon as mains power is connected.

5.2 Network Services

Inca 500 amplifiers are configured via a web page interface called. Before the configuration menus can be accessed, Inca 500 amplifiers must be connected to the same TCP/IP network as the computer or mobile device that is to be used for configuration access.

5.2.1 Wired (Ethernet) Network Connection

To connect an Inca 500 amplifier to a TCP/IP network using a wired connection (Ethernet) follow the steps below.

1. Use an Ethernet cable to connect the Inca 500 amplifier rear panel Network Control socket to a free socket on a network router or switch, or directly to an Ethernet equipped laptop or desktop computer.
2. Connect the Inca 500 amplifier to mains power using the supplied mains cable. Wait for the front panel Network indicator to illuminate green to indicate that the amplifier has network connectivity.
3. The Inca 500 amplifier default LAN IP address is 192.168.64.100. Configure the laptop or desktop computer for a fixed IP address in the same IP range; eg. 192.168.64.10, with Subnet mask of 255.255.255.0 (or prefix 24) and set the Gateway to 192.168.64.1.
4. Open a laptop or desktop web browser and enter the address <http://192.168.64.100>. The Inca 500 Web App interface will open to enable amplifier configuration as required.

Note: Inca 500 amplifiers can be configured to use DHCP for network connection if required. However, if an Inca 500 amplifier using DHCP is power cycled, it is possible that the TCP/IP network router will assign it a different IP address, leaving its configuration page inaccessible via the previous address. If this occurs, a network scanning app can be used to identify the new IP address. DHCP and Fixed IP address option settings can be found in the Settings Tab menu described in Section 5.3.

5 Configurations

5.2.2 Wireless (WiFi) Network Connection

To connect an Inca 500 amplifier to a TCP/IP network using a wireless connection (WiFi) follow the steps below.

1. With the Inca 500 amplifier connected to mains power, wait for the front panel WiFi indicator to illuminate green.
2. Use a mobile, laptop or desktop device to search for available WiFi networks. Connect to, Inca 500 (product serial number)' using the password, 'password'. The amplifier serial number can be found on its rear panel.
3. Open a computer or mobile device web browser and enter the IP address: 192.168.4.1. The Inca 500 Web App interface will open to enable amplifier configuration as required.
4. Select the Web App Settings Tab followed by WiFi > WiFi Mode > Client to configure the amplifier to connect to the required WiFi network. The WiFi network name and password will be required.

It is strongly recommended that the Inca 500 amplifier Access Point WiFi password is changed following initial wireless connection.

5 Configurations

5.3 Configuration Menus

Opening a web browser that is network connected to an Inca 500 amplifier initially displays the Inca 500 Web App Dashboard illustrated in figure 5.1. The Dashboard is the 'home' page from which all other configuration options can be accessed.

The Dashboard displays the amplifier status, output zones and the configuration menu tabs. It also enables immediate access to zone volume control. The functions available under each configuration menu tab are described in the following sections.

5.3.1 Input Tab

The Input Tab provides naming, mono/stereo selection, sensitivity, and gain trim for each amplifier input channel. An internal pink noise source, provided for system testing and set up, can also be enabled or disabled, and adjusted for gain via the Input Tab. Figure 5.2 illustrates the Input Tab.

Note: When adjusting input gain, the input level display should remain green. If it displays red, the input gain should be reduced.

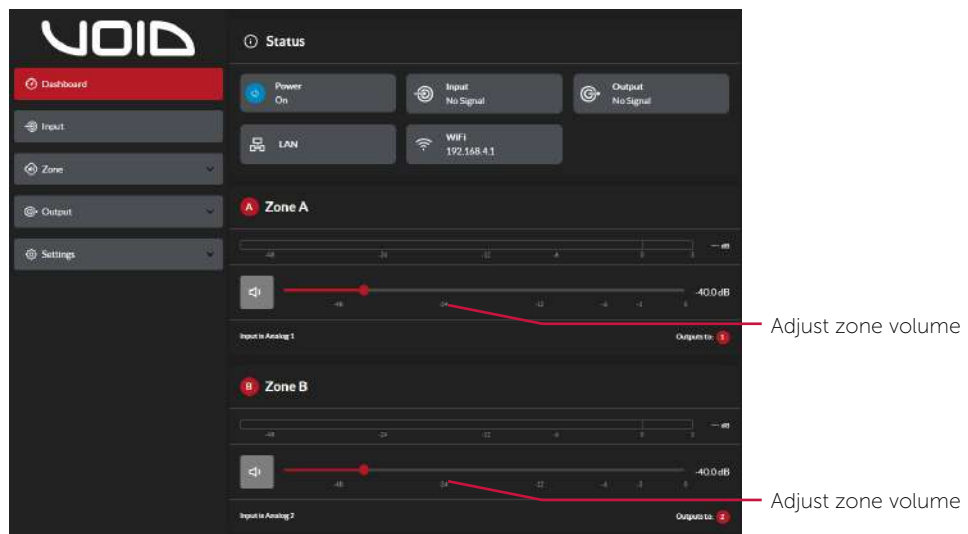

Figure 5.1: Configuration Dashboard display

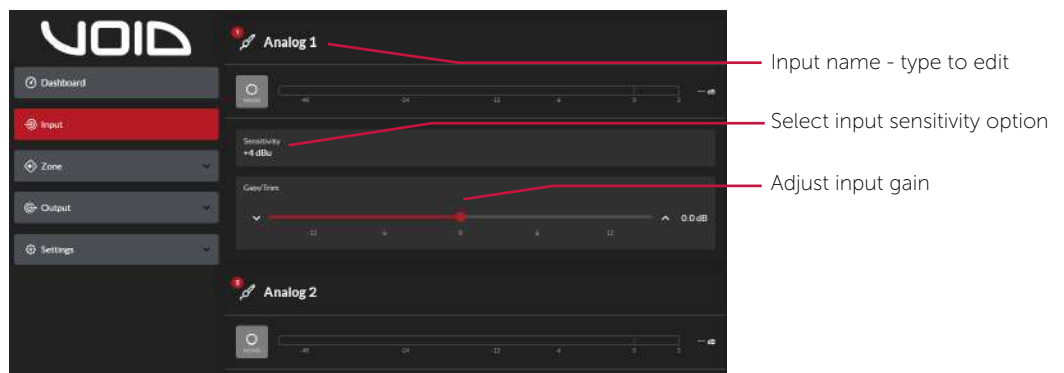

Figure 5.2: Input Tab display

5 Configurations

5.3.2 Zone Tab

The Zone Tab enables installation zones to be defined and named, and provides access to further sub-menus. Zones might be bar or restaurant areas for example, or different rooms in a home. For all Zone Tab menus, the installation zone under configuration is selected by highlighting one of the zone identifiers (A, B, C or D) at the top of the page. Figure 5.3 illustrates the Zone Tab.

- The Source menu option enables inputs to be assigned to zones.
- The GPIO Volume Control option enables external volume control to be applied to individual zones. The GPIO configuration menu can be found under the Settings Tab.
- The Compressor option enables default or custom signal compression to be applied to individual installation zones.

Note: Compression can be useful to reduce the volume difference between loud and quiet audio material. The lower the compression threshold is set, the more the difference between loud and soft will be reduced. The overall zone volume may need to be increased when compression is used. The default compression parameters are appropriate for most installations.

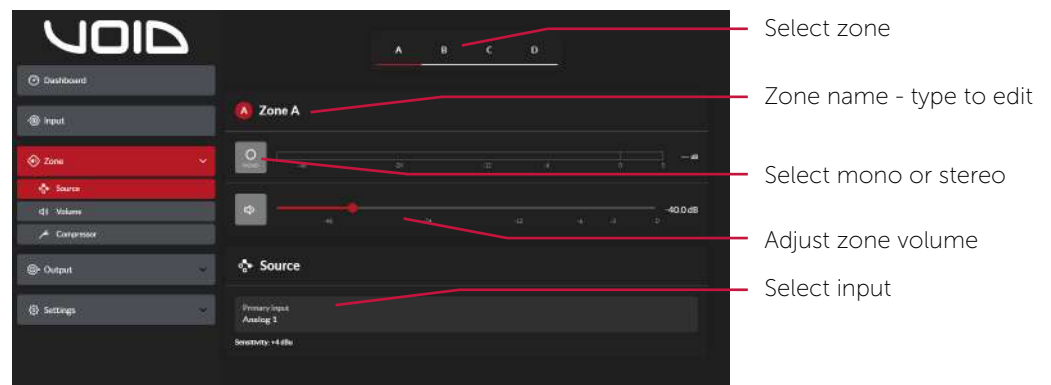

Figure 5.3: Zone Tab display

5 Configurations

5.3.3 Output Tab

The Output Tab enables amplifier outputs to be named and provides access to further sub-menus. For all Output Tab menus, the amplifier output under configuration is selected by highlighting one of the output identifiers (1, 2, 3 or 4) at the top of the display. The Output Tab also enables Speaker Preset configurations to be created, exported, imported or cleared. Figure 5.4 illustrates the Output Tab.

- The Routing menu enables zones to be assigned to amplifier outputs.

Note: Routing for zones specified as stereo will automatically offer three output options: left channel, right channel or summed mono. The summed mono signal can potentially be used to drive a mono subwoofer.

- The Delay menu enables delay to be applied to individual amplifier outputs.
- The Equalizer menu enables parametric equalization to be applied to individual amplifier outputs. Equalizer settings configured for one amplifier output can be copied and applied to other outputs.

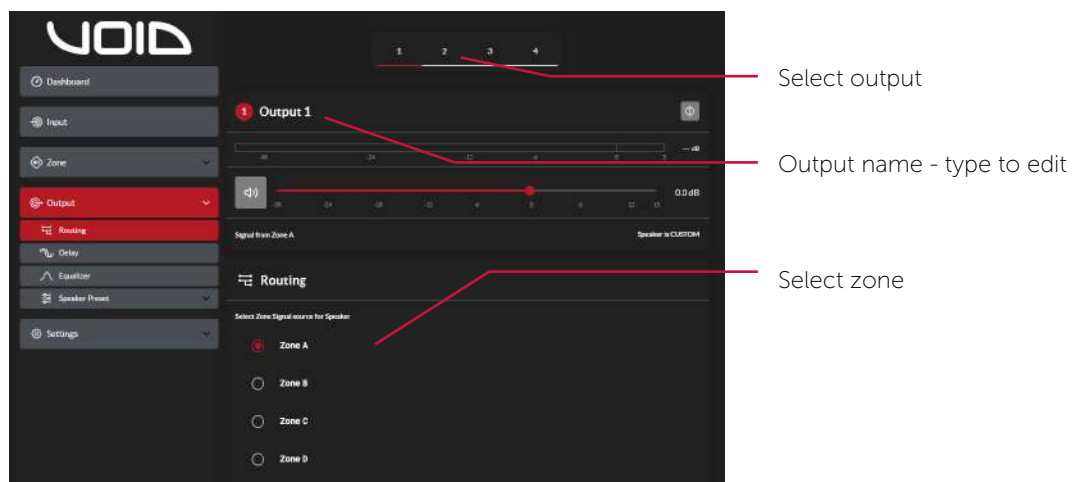

Figure 5.4: Output Tab display

5 Configurations

- The Speaker Preset menu enables speaker parameters to be adjusted, and preset configurations to be created. Speaker Presets can be simply applied to the selected amplifier output or exported, imported or cleared. The preset configurations can include any or all of the parameters described in the following paragraphs and can be protected to prevent inadvertent modification. Figures 5.5 to 5.7 illustrate the application of speaker presets.

Note: When the Speaker Preset menu is initially selected, the preset menu parameters will display only once the “Create Custom” button is selected.

Speaker Preset data provided by third parties for use with specific speakers can be imported and applied to amplifier outputs. To import speaker preset parameters follow the steps described below and illustrated in the diagrams.

1. Select the IMPORT option from the Speaker Preset menu. If no import option is visible, select CLEAR to delete any existing speaker preset data.
2. Select the appropriate '.zcp' format speaker preset data file to import. The preset data will be applied to the selected amplifier output as soon as the file import is complete.

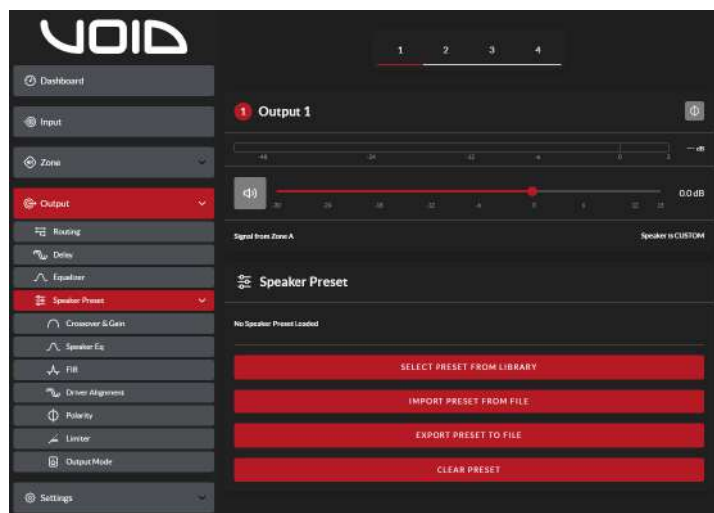

Figure 5.5: Speaker Preset Parameters

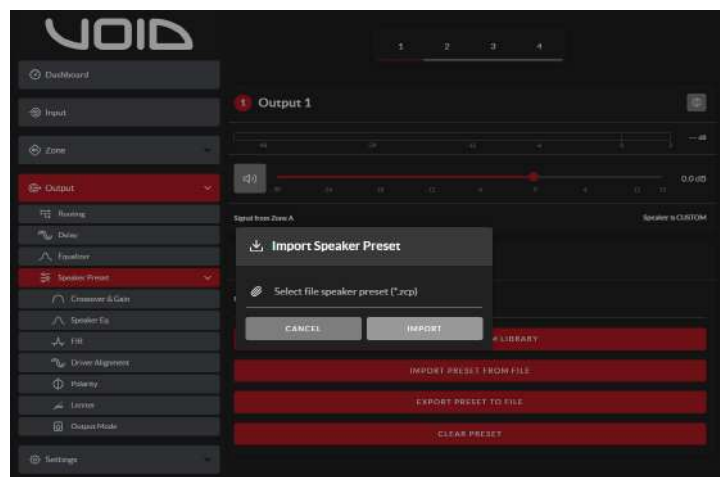

Figure 5.6: Speaker Preset import file selection

5 Configurations

5.3.4 Speaker Preset Menu Parameters

- The Crossover & Gain preset menu enables high or low-pass crossover filters and gain adjustment to be applied to individual amplifier outputs.
- The Speaker EQ preset menu enables parametric equalization to be applied to individual amplifier outputs.
- The FIR preset menu enables FIR (Finite Impulse Response) based equalization filter coefficients generated by external speaker measurement software to be imported and applied to individual amplifier outputs.

Note: FIR coefficient files in either .csv or .txt format can be imported.

- The Driver Alignment preset menu enables delay to be applied to individual amplifier outputs.
- The Polarity preset menu enables the polarity of individual amplifier outputs to be reversed.
- The Limiter preset menu enables signal limiting to be applied to individual amplifier outputs. Clip limiting, peak limiting and RMS limiting can be individually or collectively engaged. The Peak limiter can be set to either automatic or custom parameter values. The RMS limiter has default parameter values that can be adjusted but has no automatic option.

Note: In automatic mode, the peak limiter parameters adjust automatically in response to Crossover & Gain high-pass filter settings.

- The Output Mode preset menu enables individual amplifier outputs to be switched off or configured for Lo-Z or Hi-Z modes. In Hi-Z modes, a high-pass filter can also be configured and applied to the output. The number of outputs available will depend on the amplifier model, input setup and zone setup. For example, a two output amplifier will have two outputs available if Lo-Z mode is selected but only one output available if Hi-Z mode is selected.

Note: Use of a high-pass filter with Hi-Z mode loudspeakers is useful to avoid the possibility of distortion caused by low frequency line transformer saturation. Begin with the default filter setting of 70Hz. If low frequency distortion is still audible, increase the frequency setting one step at a time until the distortion is no longer audible.

5 Configurations

5.3.5 Settings Tab

The Settings Tab enables miscellaneous amplifier settings to be configured and installation data to be recorded. The Settings Tab provides access to further sub-menus. Figure 5.10 illustrates the Settings Tab.

- The System Information menu provides text fields for the recording of installation data.
- The Device menu records amplifier specific information such as the model number and firmware version. A firmware update routine and identifier button can also be found under the Device menu.
- The Backup & Restore menu enables amplifier configuration data to be downloaded to an external archive, and enables previously saved configuration files to be uploaded and adopted by the currently connected amplifier.
- The Power Management menu enables various automatic switch-on options to be engaged. The Power Management menu also offers timed Standby and Mute functions.
- The GPIO menu enables configuration of the multi-purpose GPIO interface pins.
- The LAN menu enables configuration and reset of the wired network options and parameters.
- The WiFi menu enables configuration and reset of the wireless network options and parameters.

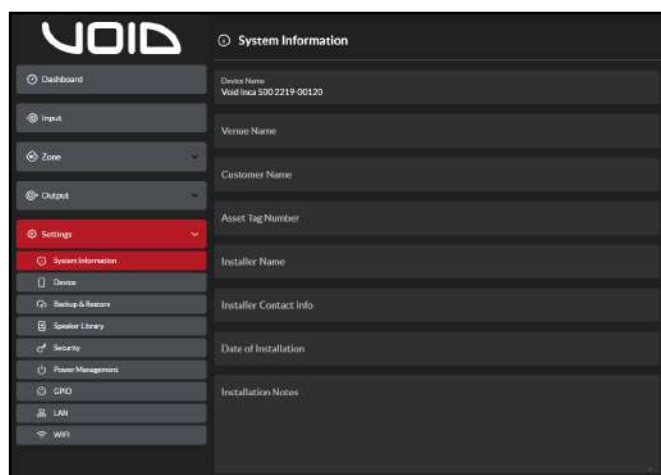

Figure 5.7: Settings Tab menu

5.4 Setup and Signal Routing

Thanks to their network based configuration features, Inca 500 amplifiers offer considerable versatility in terms of sources, signal routing, installation zones and output modes. Inputs can be freely assigned to installation zones, and those zones assigned freely to the available amplifier outputs in either Lo-Z or Hi-Z modes.

This versatility enables, for example, one amplifier simultaneously to drive both Lo-Z and Hi-Z speakers, or for different inputs to be routed to different output zones.

The following paragraphs describe and illustrate the recommended procedure for configuring input, zone and output routing. A general signal flow schematic is also illustrated in figure 5.11.

5 Configurations

5.4.1 Input Setup

Open the configuration Dashboard and select the Input Tab. The Input Tab is shown in figure 5.2.

- To edit default input names simply select and type in the Input Name field.
- Define a mono or stereo input by selecting the appropriate option. Defining a stereo input will reduce the total number of discrete inputs available.
- Select an input sensitivity option from the drop-down menu: +14dB, +4dB, -10dB and 'microphone' options are available. Generally, the +14dB or +4dB options are appropriate for 'professional audio' source hardware with balanced outputs, while the -10dB option is more appropriate for 'consumer audio' source hardware with unbalanced outputs. The 'microphone' option provides the significantly greater sensitivity required for microphones.
Note: Only dynamic microphones are suitable for connection. Phantom power for condenser microphones is not provided.
- If necessary, adjust the input gain using the slider or up/down icons. Gain adjustment is intended to be used for fine output level adjustment following initial use.

5.4.2 Zone Setup & Routing

Open the configuration Dashboard and select the Zone Tab. The Zone Tab is shown in figure 5.3.

- Select the zone to be configured. The number of zones available and their channel format (stereo or mono) will depend on the input setup and output mode (Lo-Z or Hi-Z).
- A four output amplifier can have the following zones configured:
 - 2 x stereo Lo-Z zones
 - 4 x mono Lo-Z zones
 - 2 x mono Hi-Z zone
 - 1 x mono Hi-Z zone + 1 x stereo Lo-Z zone
 - 1 x mono Hi-Z zone + 2 x mono Lo-Z zones

Note: When configured in Hi-Z mode Inca 500 amplifiers operate in 'bridged' mode where the output of two channels is combined. This means that the number of output channels available in Hi-Z mode is half that available in Lo-Z mode .

Note: Mono signals might be mono at source, created though combining the left and right channels of a stereo signal (summed mono) or treating the left and right channels of a stereo signal independently (split mono).

5 Configurations

- Name zones by typing in the Zone Name field.
- Adjust the zone volume if required by using the slider.
- Define a mono or stereo zone by selecting the appropriate option. Defining a stereo zone will reduce the total number of further zones available.
- Specify an input for the zone by selecting from the drop-down menu. Selecting a stereo input for a mono zone will automatically sum the stereo channels to mono.

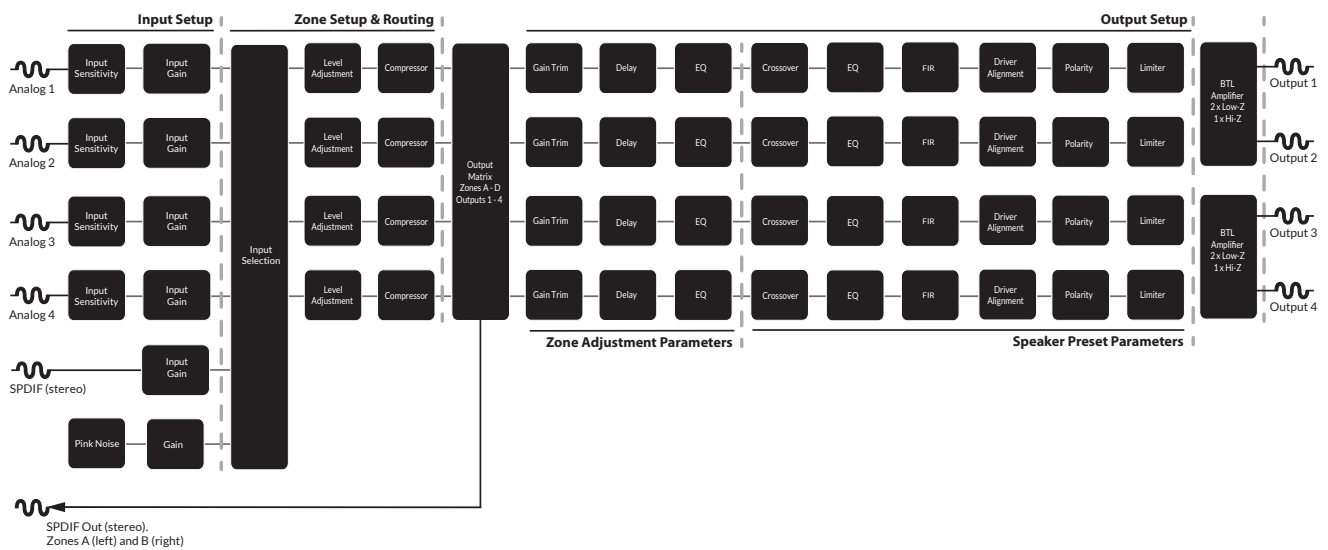



Figure 5.8: Signal Flow Schematic

5 Configurations

5.5 GPIO Setup and Connection

Inca 500 amplifiers provide a GPIO socket that enables remote control of volume, standby, mute and trigger functions. The GPIO connector pin functions are described in the GPIO Settings menu illustrated in figure 5.12.

 The connection of GPIO based remote volume control and standby/mute are illustrated in figure 5.10 and 5.11 respectively.

 Note: The GPIO connector must not be used for any unintended purpose. Amplifier damage may result from incorrect use of GPIO.

 Note: Shielded cable must be used when connecting standby switches and potentiometers via GPIO.

 Note: GPIO Pin 8 has a low output impedance and is able to supply a maximum current of 10mA.

Note: GPIO Pin 1 and Pin 3 both offer ground connections: Pin 1 is connected directly to the amplifier chassis.

Pin 3 is connected to the chassis via a 220 Ohm resistor. The 'soft ground' connection of Pin 3 is potentially useful for managing ground loops that may cause audible hum.

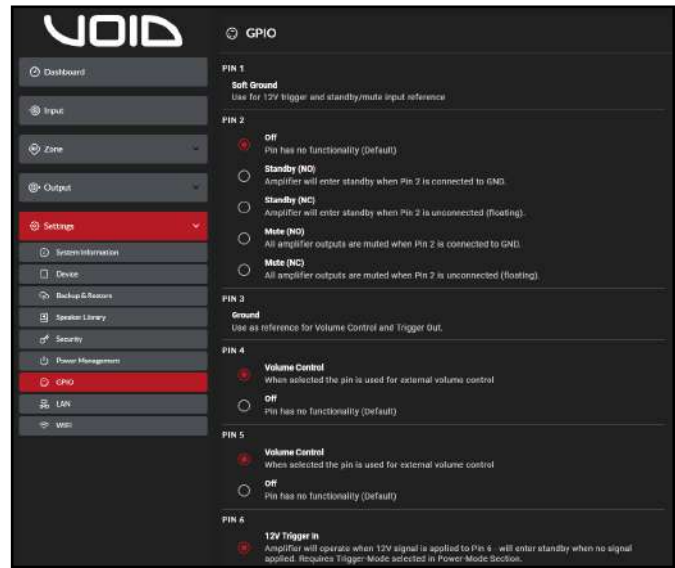

Figure 5.9: GPIO Settings Menu

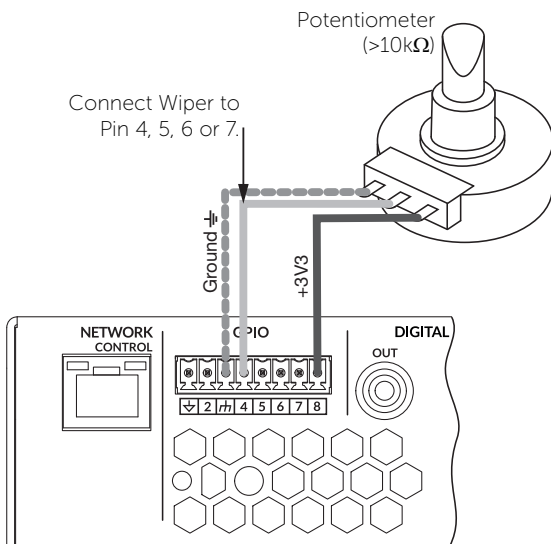

Figure 5.10: Potentiometer connections for remote volume control via GPIO.

Note: Figure 6.3 illustrates use of the GPIO connector.

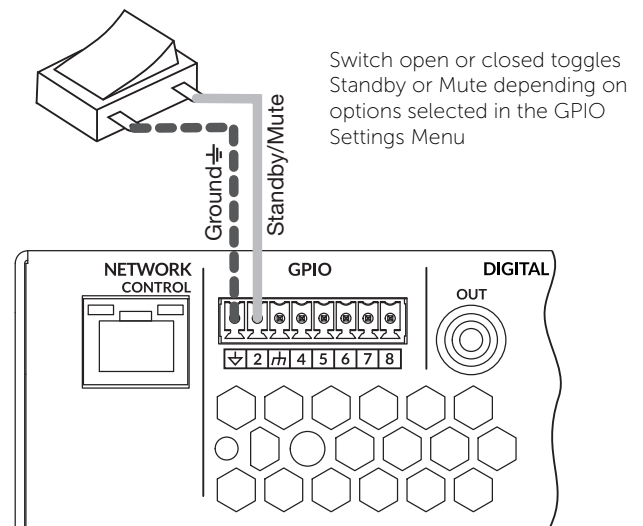

Figure 5.11: Connections for remote standby/mute switch via GPIO.

Note: Figure 6.3 illustrates use of the GPIO connector.

6 Connections

6.1 Mains Power Connection

Inca 500 amplifiers incorporate a power factor corrected universal power supply and can be used with mains input voltage from 100V AC to 240V AC, 50/60Hz. Use the mains cable supplied with the amplifier.

Inca 500 amplifiers have no mains power switch and are operational as soon as mains power is connected. Ensure that all signal, GPIO and output connections are made before connecting the amplifier to mains power.

6.2 Input Connection

All Inca 500 amplifier models provide four balanced or unbalanced analog audio inputs and a stereo S/PDIF digital audio input. Any input channel can be routed to any output channel. Input routing options can be configured via the amplifier network interface. See Section 5 of this manual.

Analog Inputs

Inca 500 analog inputs are of line level format with a default input sensitivity of +4dBu (full output voltage swing/sensitivity) in all output modes. Input signal levels up to +24dBu can be handled without input clipping. Input sensitivity options can be set via the amplifier network interface. See Section 5 of this manual.

Balanced input connections to the amplifiers are made via male 'Euro Block' connectors. Connecting cables to the supplied female input connectors is illustrated in figure 6.2.

Unbalanced input connections to the amplifiers are made via RCA phono sockets.

Digital Inputs

Inca 500 S/PDIF stereo digital audio input connections are made via a single RCA Phono socket

Note: An S/PDIF digital audio output socket is also fitted. The S/PDIF output signal by default reflects the input to amplifier installation zones A & B and is intended to be used for daisy-chaining Inca 500 amplifiers.

Note: 75Ω RCA Phono cables specifically intended for digital audio should always be used for S/PDIF connections.

6.3 Output Connections

Output connections from the amplifiers are achieved via male 'Euro Block' connectors. Ensure that speaker connection polarity is correct throughout the installation:

In the case of Lo-Z speaker connections, positive (+) amplifier terminals should always be connected to positive speaker terminals and negative (-) amplifier terminals always connected to negative speaker terminals.

In the case of Hi-Z speaker connections, the two speaker cable conductors should be connected between the positive (+) terminal of Output 1 and the negative terminal (-) of Output 2, and likewise for Outputs 3 and 4.

6 Connections

Output mode options (Lo-Z or Hi-Z) can be configured via the amplifier network interface. See Section 5 of this manual.

Connecting cables to the supplied female output connector is illustrated in Figure 6.4.

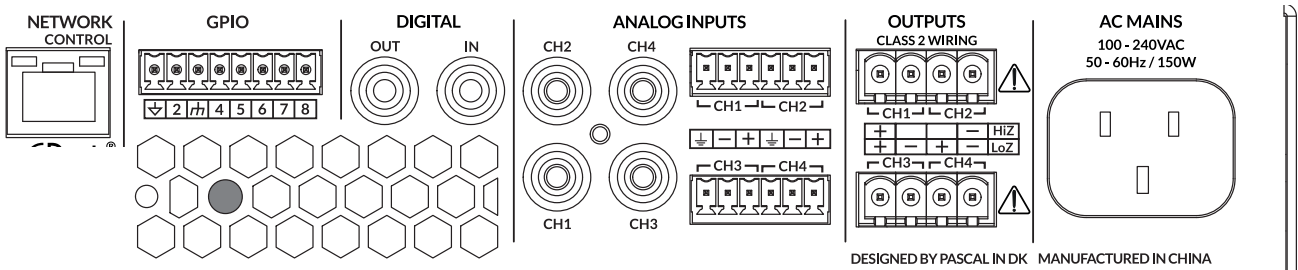

Figure 6.1: Inca 500 rear panel connections

6.4 Speaker Cable Gauge

Inca 500 speaker connection cable gauge should be chosen appropriately to reflect the type of installation. The adjacent tables specify the appropriate cable gauge for less than 0.5dB cable loss with different installation types and cable lengths.

6.5 GPIO Connections

If any Inca 500 GPIO functionality is required, cables will need to be

Cable Gauge Table
Lo-Z installations. 4Ω & 8Ω loads

Cable Cross Section (mm ²)	Cable Gauge (US)	Max Cable Length (metres, 4Ω load)	Max Cable Length (metres, 8Ω load)
0.5	≈20	2	5
0.75	≈18	4	8
1.5	≈16	6	12
2.0	≈14	9	19
4.0	≈12	14	30

Cable Gauge Table
70V Hi-Z installations. 60W & 125W power

Cable Cross Section (mm ²)	Cable Gauge (US)	Max Cable Length (metres, (125W/channel)	Max Cable Length (metres, (250W/channel)
0.5	≈20	84	42
0.75	≈18	132	66
1.5	≈16	210	105
2.0	≈14	334	166
4.0	≈12	532	265

Cable Gauge Table
100V Hi-Z installations. 60W & 125W power

Cable Cross Section (mm ²)	Cable Gauge (US)	Max Cable Length (metres, (125W/channel)	Max Cable Length (metres, (250W/channel)
0.5	≈20	171	85
0.75	≈18	269	134
1.5	≈16	430	215
2.0	≈14	683	341
4.0	≈12	1087	542

6 Connections

connected to the supplied GPIO connector. Connecting cables to the GPIO connector is illustrated in Figure 6.3.

6.6 Network Connections

Inca 500 amplifiers are TCP/IP network connected devices that are configured via a web page based interface. Wired (Ethernet) and wireless (WiFi) connection options are available. Connecting Inca 500 amplifiers to a TCP/IP network is described in Section 5 of this manual.

6 Connections

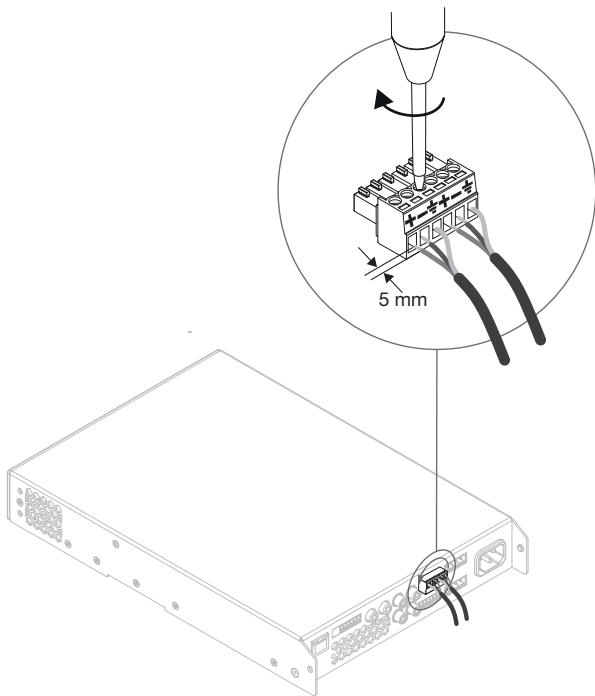

Figure 6.2: Balanced analog input cable connections.

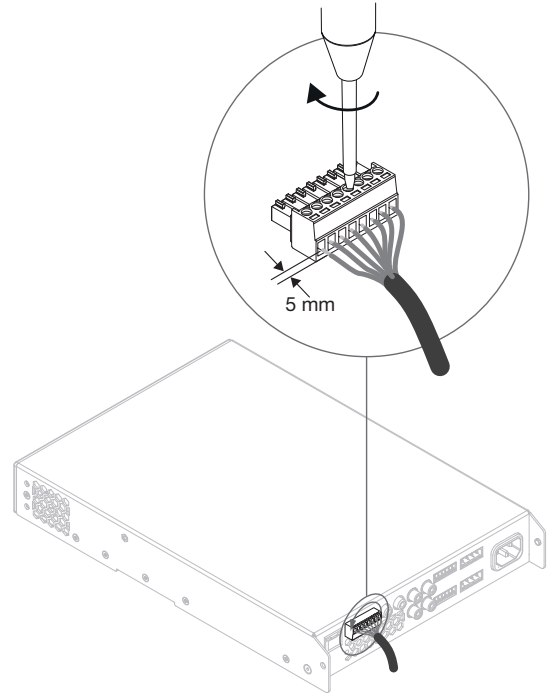

Figure 6.3: GPIO cable connections.

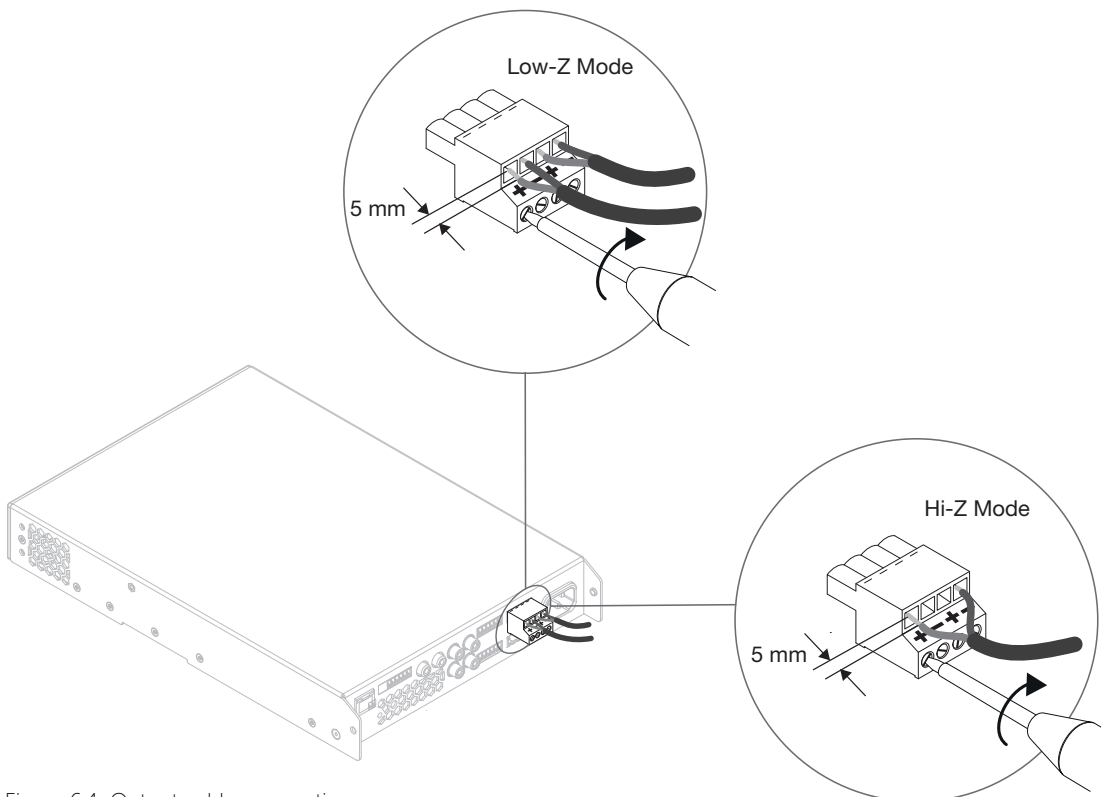

Figure 6.4: Output cable connections.



The exclamation point printed next to the output terminals of the amplifiers is, in addition to the CLASS 2 WIRING text, intended to alert users to the risk of hazardous voltages. Output connectors that could pose a risk are marked with the exclamation point. Do not touch the output terminals while the amplifier is switched on. Make all connections with the amplifier switched off.

7 Operations

Once all connections have been made and configuration options selected, Inca 500 amplifiers are ready for use. If an input signal above -60dB is present on any input, the front panel Input and Standby indicators will illuminate green to indicate normal amplifier operation. Audio will be heard from any connected speakers.

Note: Inca 500 amplifiers will not switch on from Standby Mode unless an input signal is present, a network 'ON' command is received, or an external standby switch (or 12V trigger) is operated. Standby behaviour can be configured via the Power Management menu of the Settings Tab.

Amplifier outputs will mute if no input signal is present for 5 minutes, and the amplifier will switch automatically to Standby Mode if no signal is present on any input for more than 15 minutes. Alternative standby and mute delay times can be selected via the **Settings Tab**. Amplifier cooling fan speed is temperature controlled. The fan will switch off when the amplifier enters standby mode.

7.1 Front Panel Indicators

Inca 500 amplifier front panel indicators illuminate to indicate the following operational states:

Status: Off – Mains power disconnected.
Green – Amplifier operational.
Pulse Green – Standby Mode.
Amber – GPIO triggered Standby Mode

Input: Off – No input signal present.
Green – Signal present on one or more inputs.
Amber – Signal limiting/clipping on one or more inputs.

Output: Off – No output signal present.
Green – Signal present on one or more outputs.
Amber – Signal limiting/clipping on one or more outputs.
Red – One or more channel pair is in overload/protection mode.

Network: Off – No Ethernet network detected.
Green – Ethernet network detected.

WiFi: Off – WiFi disabled.
Green – WiFi enabled.

7 Operations

7.2 Automatic Power Sharing

Inca 500 amplifiers incorporate a power sharing feature that automatically shares the total power available from the amplifier's internal power supply across each pair of output channels. If one channel temporarily demands more than the amplifier's continuous power rating while other channel is demanding less, the excess power available from the internal power supply is automatically made available to the over-power channel. Power sharing optimises the amplifier's ability to deliver maximum power into dynamic loudspeaker loads when playing music programme material.

7.3 Default Reset

Inca 500 amplifiers can be returned to their default settings via either the Control Web App Settings Tab or the hardware reset pinhole button. The reset pin-hole button is located on the underside panel of the amplifier. With the amplifier connected to mains power, use an appropriate tool to press and hold the reset pinhole button for a few seconds. The amplifier will restart with all settings in their default, unused state. All previously configured settings will be lost.

8 Specifications

Model	Inca 500
Total System Power	500 W
Output Power @ 4/8Ω	4 x 125 W
Output Power @ 70/100V*	2 x 250 W
Powershare (up to) Across all channels	2 x 250 W
Power Consumption	150W
Dimensions	44 x 220 x 319 mm (1.7 x 8.7 x 12.6 in)
Weight	2.8kg (6.2 lbs)
Output Circuitry	UMAC™ Class D - full bandwidth PWM modulator with ultra-low distortion
Output Voltage	70Vp / 140Vpp (unloaded) // Bridged 140Vp / 280 Vpp (unloaded)
Signal To Noise-Ratio	>106dB (A-weighted, 20Hz-20kHz, 8Ω load)
THD+N (typical)	< 0.05% (20Hz-20kHz, 8Ω load, 3dB below rated power)
Frequency Response	20Hz-20kHz (+0/-0.25dB (8Ω load, 3dB below rated power)
Protection Circuits	Short circuit -, DC -, Undervoltage -, Temperature - and Overload protection
Power Supply	UREC™ universal mains switch mode power supply with Power Factor Correction (PFC) and standby converter
Operating temperature	0-40°C
Operating Voltage/ Frequency	Universal Mains, 100V-240V, 50Hz-60Hz
Standby Consumption	< 0.5W
Accessories	2x Rack ears 1x ½ rack plate extension 2x ½ rack mounting 2x Rear supports
Power Ratings	1% THD @ 120Vac and 230Vac

*100V line mode is @ -1dB (≈ 90 V)

NORTH AMERICA

Void Acoustics North America

Call: +1 503 854 7134

Email: sales.usa@voidacoustics.com

HEAD OFFICE

Void Acoustics Research Ltd,
Unit 15, Dawkins Road Industrial Estate,
Poole, Dorset,
BH15 4JY
United Kingdom

Call: +44(0) 1202 666006

Email: info@voidacoustics.com



Hear. Feel. Connect.

voidacoustics.com