

VOID

Hear. Feel. Connect.

voidacoustics.com



Indigo Series

Distinct and unmistakable

USER GUIDE V2.1

©2023 Void Acoustics Research Ltd.

This user guide is subject to change without notice.
For the latest online version, visit: www.voidacoustics.com

Void Acoustics and the Void logo are registered trademarks of Void Acoustics Research Ltd. in the United Kingdom, USA and other countries; all other Void trademarks are the property of Void Acoustics Research Ltd.

Contents

1	Safety and Regulations	4	5.9	Indigo Sub Bias Q3/Q5 speakON™ wiring	16
1.1	Important Safety Instructions	4			
1.2	Limitations	4			
1.3	EC Declaration of Conformity	4	6	Mounting	17
1.4	UKCA Conformity	4	6.1	Installation Safety	17
1.5	Warranty Statement	4	6.2	Indigo 6s Wall Mounting	18
1.6	WEEE Directive	4	6.3	Indigo Sub and 6 Pro Mounting	20
			6.4	Indigo 6 Pro Wall Mounting	22
2	Unpacking and Checking	5	7	Service	24
3	About	6	7.1	Return Authorisation	24
3.1	Welcome	6	7.2	Shipping and Packing Considerations	24
3.2	Indigo Series Overview	6			
4	Specifications and Dimensions	7	8	Appendix	25
4.1	Indigo 6s	7			
4.1.1	Indigo 6s Specifications	7			
4.1.2	Indigo 6s Key Features	8			
4.1.3	Indigo 6s Dimensions	8			
4.2	Indigo 6 Pro	9			
4.2.1	Indigo 6 Pro Specifications	9			
4.2.2	Indigo 6 Pro Key Features	10			
4.2.3	Indigo 6 Pro Dimensions	10			
4.3	Indigo Sub	11			
4.3.1	Indigo Sub Specifications	11			
4.3.2	Key Features	11			
4.3.3	Indigo Sub Dimensions	12			
4.3.4	Indigo Sub Impedance Graph	12			
5	Cable and Wiring	13			
5.1	Electrical Safety	13			
5.2	Cable Consideration for Fixed Installations	13			
5.3	Phoenix Connector	13			
5.4	Indigo 6s/Pro Wiring Diagram	14			
5.5	Indigo 6s/Pro Bias D1/Q1/Q2 Phoenix Wiring	14			
5.6	Indigo 6s/Pro Bias Q3/Q5 speakON™ Wiring	15			
5.7	Indigo Sub Wiring Diagram	15			
5.8	Indigo Sub Bias D1/Q1/Q2 Phoenix wiring	16			

1 Safety and Regulations

1.1 Important safety instructions



The lightning flash with an arrowhead symbol within an equilateral triangle is intended to alert the user to the presence of uninsulated "dangerous voltage" within the product's enclosure that may be of sufficient magnitude to constitute a risk of electric shock to persons.



The exclamation point within an equilateral triangle is intended to alert the user of the presence of important operating and maintenance (servicing) instructions in the literature accompanying the appliance.

Safety instructions - read this first

1. Read these instructions.
2. Keep these instructions.
3. Heed all warnings.
4. Follow all instructions.
5. Do not use this apparatus near water.
6. Clean only with a dry cloth.
7. Do not block any ventilation openings. Install in accordance with the manufacturer's instructions.
8. Do not install near any heat source such as radiators, heat registers, stoves, or other such apparatus that produce heat.
9. Do not defeat the safety purpose of the grounding-type plug. A grounding type plug has two blades and a third grounding prong. The third prong is provided for your safety. If the provided plug does not fit into your outlet, consult an electrician for replacement of the obsolete outlet.
10. Protect power cords from being walked on or pinched particularly at plugs, convenience receptacles, and the point where they exit the apparatus.
11. Only use attachments and accessories specified by Void Acoustics.
12. Only use with the cart, stand, tripod, bracket, or table specified by the manufacturer, or sold with the apparatus. When a cart is used, use caution when moving the cart/apparatus combination to avoid injury from tip-over.
13. Unplug the apparatus during lightning storms or when unused for long periods of time.
14. Refer all servicing to qualified service personnel. Servicing is required when the apparatus has been damaged in any way, such as when the power-supply cord or plug is damaged, liquid has been spilled or objects have fallen into the apparatus, the apparatus has been exposed to rain or moisture, does not operate normally, or has been dropped.
15. Since the mains power supply cord attachment plug is used to disconnect the device, the plug should always be easily accessible.
16. Void loudspeakers can produce sound levels capable of causing permanent hearing damage from prolonged exposure. The higher the sound level, the less exposure needed to cause such damage. Avoid prolonged exposure to the high sound levels from the loudspeaker.

1.2 Limitations

This guide is provided to help familiarise the user with the loudspeaker system and its accessories. It is not intended to provide comprehensive electrical, fire, mechanical and noise training and is not a substitute for industry-approved training. Nor does this guide absolve the user of their obligation to comply with all relevant safety legislation and codes of practice. While every care has been taken in creating this guide, safety is user-dependent and Void Acoustics Research Ltd cannot guarantee complete safety whenever the system is rigged and operated.

1.3 EC declaration of conformity

For EC Declaration of Conformity please go to:

www.voidacoustics.com/eu-declaration-loudspeakers

1.4 UKCA marking

For details of the UKCA marking go to:

www.voidacoustics.com/uk-declaration-loudspeakers

1.5 Warranty statement

For warranty statement go to:

<https://voidacoustics.com/terms-conditions/>

1.6 WEEE directive

If the time arises to throw away your product, please recycle all the components possible.



This symbol indicates that when the end-user wishes to discard this product, it must be sent to separate collection facilities for recovery and recycling. By separating this product from other household-type waste, the volume of waste sent to incinerators or land-fills will be reduced and natural resources will thus be conserved.

The Waste Electrical and Electronic Equipment Directive (WEEE Directive) aims to minimise the impact of electrical and electronic goods on the environment. Void Acoustics Research Ltd complies with the Directive 2002/96/EC and 2003/108/EC of the European Parliament on waste electrical and electronic equipment (WEEE) in order to reduce the amount of WEEE that is being disposed of in land-fill sites. All of our products are marked with the WEEE symbol; this indicates that this product must NOT be disposed of with other waste. Instead it is the user's responsibility to dispose of their waste electrical and electronic equipment by handing it over to an approved reprocessor, or by returning it to Void Acoustics Research Ltd for reprocessing. For more information about where you can send your waste equipment for recycling, please contact Void Acoustics Research Ltd or one of your local distributors.

2 Unpacking and Checking

All Void Acoustics products are carefully manufactured and thoroughly tested before being despatched. Your dealer will ensure that your Void products are in pristine condition before being forwarded to you but mistakes and accidents can happen.

Before signing for your delivery:

- Inspect your shipment for any signs of contamination, abuse or transit damage as soon as you receive it
- Check your Void Acoustics delivery fully against your order
- If your shipment is incomplete or any of its contents are found to be damaged; inform the shipping company and inform your dealer.

When you are removing your Indigo Series loudspeaker from its original packaging:

- Indigo Series loudspeakers come double boxed are stapled shut; take care when unpacking and removing the staples to avoid injury or damage to the loudspeaker
- If you need to place the loudspeaker on a flat surface ensure you use a lint free product to protect the finish
- When you have removed the Indigo Series loudspeaker from the packaging inspect it to ensure there is no damage and keep all original packaging in case it needs to be returned for any reason.

See section 1.5 for warranty conditions and see section 7 if your product needs service.

3 About

3.1 Welcome

Many thanks for purchasing this Void Acoustics Indigo Series loudspeaker. We truly appreciate your support. At Void, we design, manufacture and distribute advanced professional audio systems for the installed and live sound market sectors. Like all Void products, our highly skilled and experienced engineers have successfully combined pioneering technologies with ground-breaking design aesthetics, to bring you superior sound quality and visual innovation. In buying this product, you are now part of the Void family and we hope using it brings you years of satisfaction. This guide will help you both use this product safely and ensure it performs to its full capability.

3.2 Indigo Series overview

The stunning Indigo series combines futuristic looks with powerful audio performance to bring a new level of sophistication for enviable venues. Indigo is the ultimate in sleek styling and brings a new level of sonic richness to commercial installations.

4 Specifications and Dimensions

4.1 Indigo 6s

4.1.1 Indigo 6s specifications

Frequency response	70 Hz - 23 kHz ± 3 dB
Efficiency ¹	90 dB 1W/1m
Nominal impedance	8 Ω
Power handling ²	80 W AES
Maximum output ³	108 dB cont, 111 dB peak
Driver configuration	1 x 6.5" LF, 1 x 1" soft dome tweeter
Dispersion	90°H x 90°V
Connectors	Phoenix connector
Height	273 mm (10.7")
Width	209 mm (8.2")
Depth	163 mm (6.4")
Weight	2.2 kg (4.9 lbs)
Enclosure	Fibreglass
Rigging	6s wall bracket (supplied)
Finish	Smooth cellulose
Grill	Perforated steel with foam filter

¹ Measured in half space ² AES2 - 1984 compliant ³ Calculated

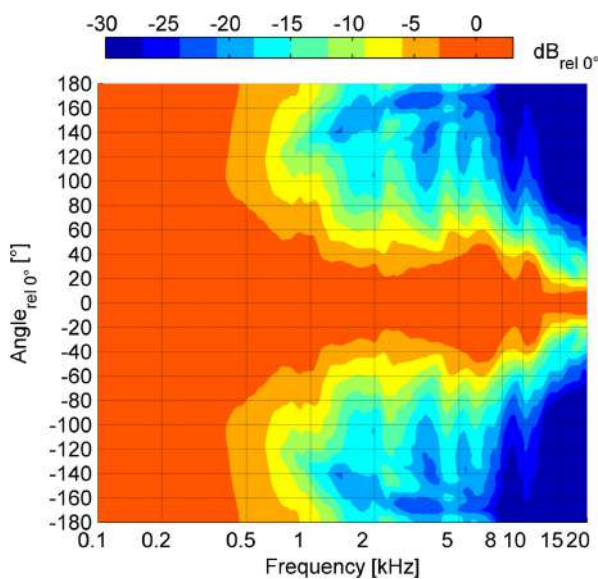

Figure 4.1: Horizontal directivity isobars

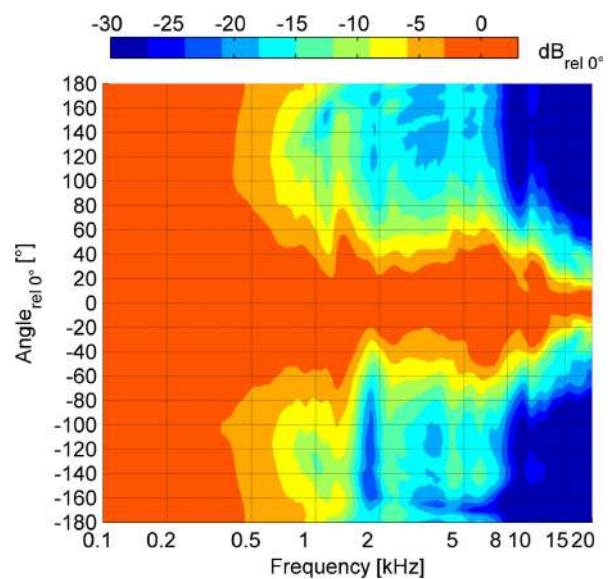

Figure 4.2: Vertical directivity isobars

4 Specifications and Dimensions

4.1.2 Indigo 6s key features

- Passive 6.5" two-way surface mount loudspeaker
- Ultra-modern appearance for style-led environments
- Wide 90°H x 90°V dispersion pattern
- Sculpted fibreglass enclosure
- 6.5" low frequency transducer
- 1" soft dome high frequency tweeter
- Dedicated wall bracket, optional subwoofer mount bracket
- High gloss metallic or fine textured matt finish

4.1.3 Indigo 6s dimensions

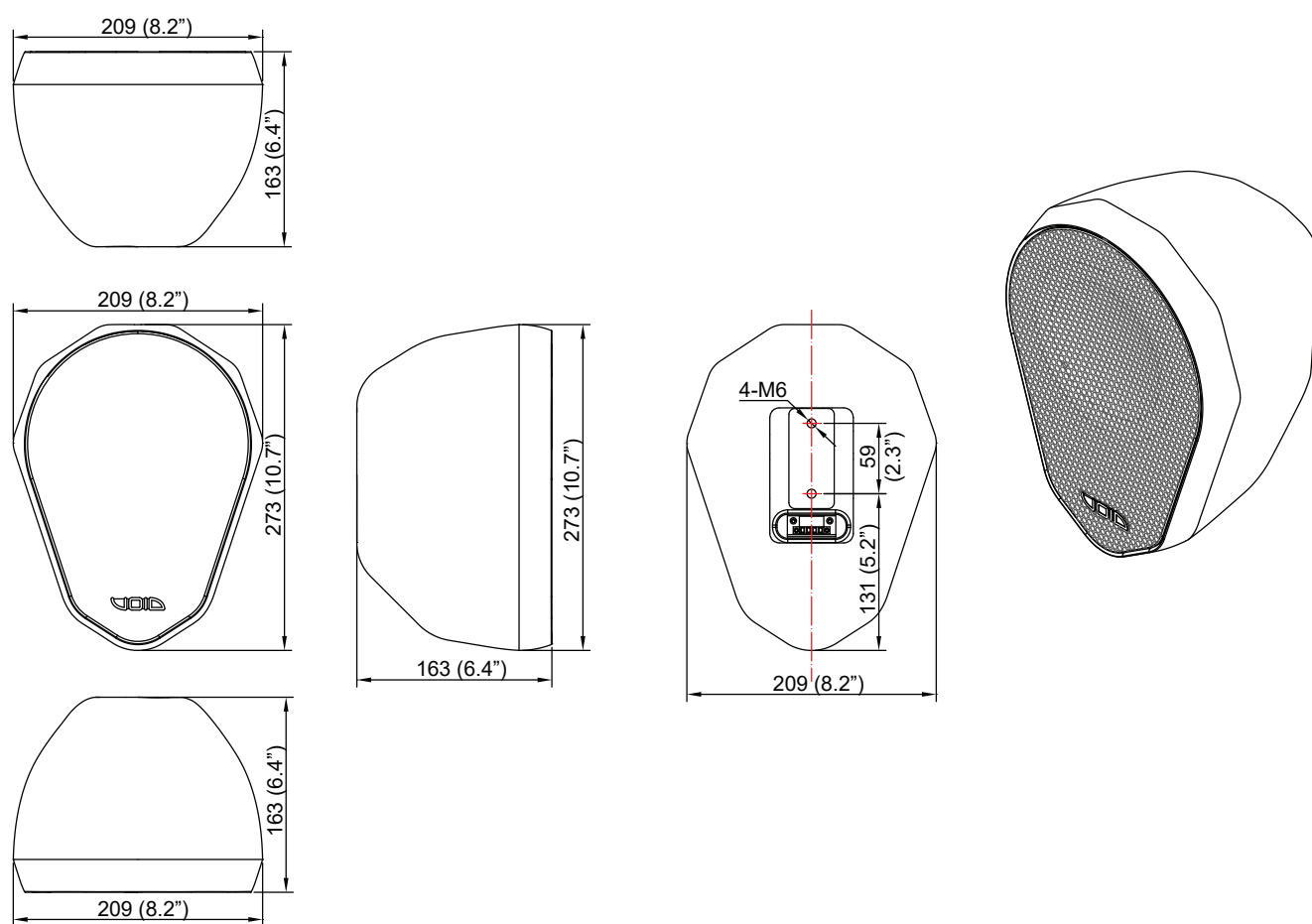

Figure 4.3: Dimensions

4 Specifications and Dimensions

4.2 Indigo 6 Pro

4.2.1 Indigo 6 Pro specifications

Frequency Response	68 Hz - 21 kHz \pm 3 dB
Efficiency ¹	93 dB 1W/1m
Crossover Points	2.2 kHz passive
Nominal Impedance	8 Ω
Power Handling ²	200 W AES
Maximum Output ³	115 dB cont, 118 dB peak
Driver Configuration	1 x 6.5" LF, 1 x 1" coaxial high frequency compression driver
Dispersion	90°H x 90°V
Protection	HF electronic device
Connectors	Phoenix connector
Height	273 mm (10.7")
Width	209 mm (8.2")
Depth	163 mm (6.4")
Weight	5.2 kg (11.5 lbs)
Enclosure	Fibreglass
Rigging	i6 wall bracket (supplied) i12 bracket to mount Indigo 6s above Indigo 12 (optional)
Finish	Smooth cellulose
Grill	Perforated steel with foam filter

¹ Measured in half space ² AES2 - 1984 compliant ³ Calculated

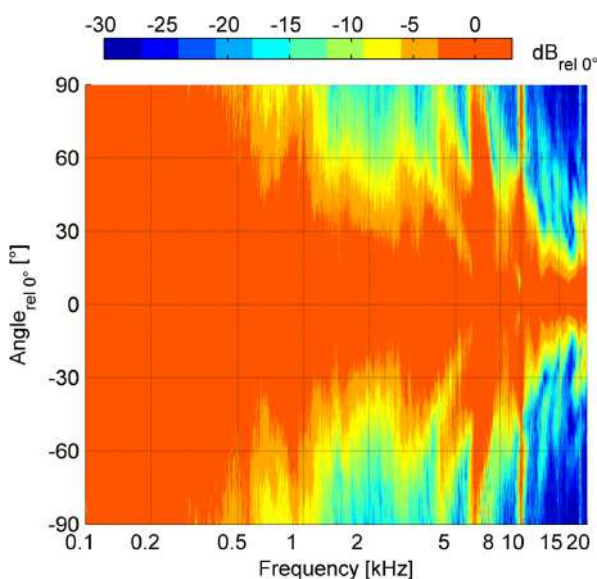

Figure 4.4: Horizontal directivity isobars

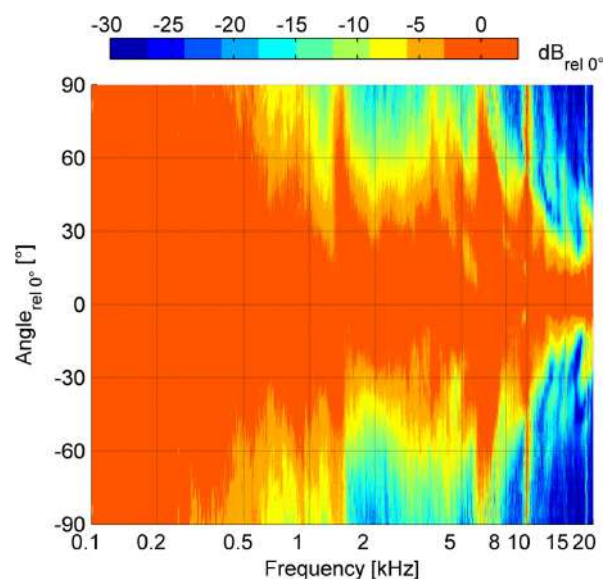

Figure 4.5: Vertical directivity isobars

4 Specifications and Dimensions

4.2.2 Indigo 6 Pro key features

- Passive 6.5" two-way surface mount loudspeaker
- Ultra-modern appearance for style-led environments
- True point source radiation
- Wide 90°H x 90°V dispersion pattern
- Sculpted fibreglass enclosure
- 6.5" low frequency driver
- 1" coaxial high frequency compression driver
- Dedicated wall bracket, optional subwoofer mount bracket
- High gloss metallic or fine textured matt finish

4.2.3 Indigo 6 Pro dimensions

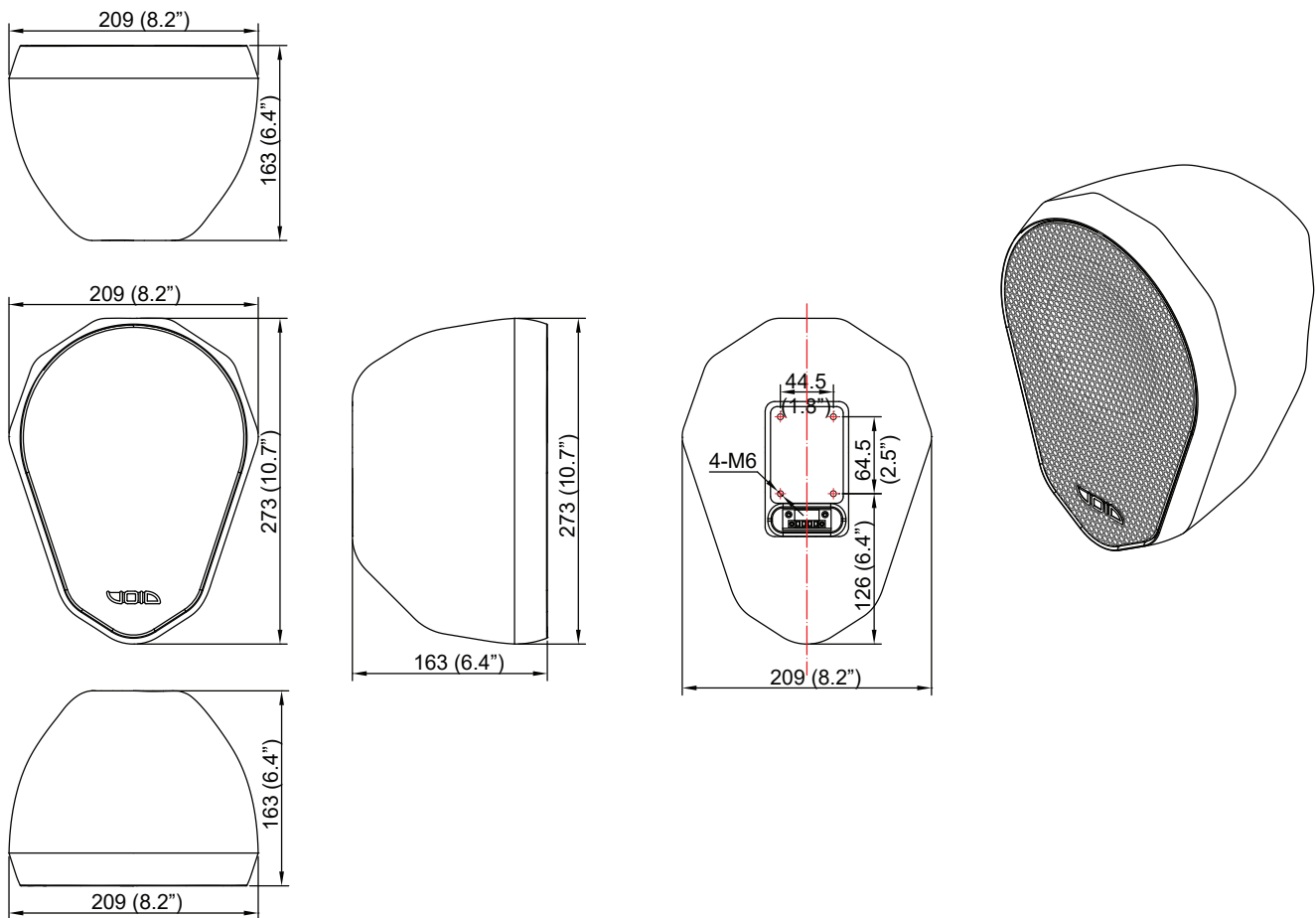

Figure 4.6: Dimensions

4 Specifications and Dimensions

4.3 Indigo Sub

4.3.1 Indigo Sub specifications

Frequency Response	40 Hz - 160 Hz ± 3 dB
Efficiency ¹	92 dB 1W/1m
Crossover Points	80 Hz - 160 Hz passive
Nominal Impedance	8 Ω
Power Handling ²	600 W AES
Maximum Output ³	117 dB cont, 123 dB peak
Driver Configuration	1 x 12" LF
Connectors	4 mm binding posts
Height	521 mm (20.5")
Width	395 mm (15.5")
Depth	336 mm (13.2")
Weight	21 kg (46.3 lbs)
Enclosure	Fibreglass
Rigging	i12 bracket to mount Indigo 6s above Indigo 12 (optional)
Finish	Smooth cellulose or fine textured matt
Grill	Perforated steel with foam filter

¹ Measured in half space ² AES2 - 1984 compliant ³ Calculated

4.3.2 Indigo Sub Key features

- Compact 12" reflex loaded subwoofer
- Ultra-modern appearance for style-led environments
- Sculpted low resonance fibreglass enclosure
- 12" low frequency transducer
- Optional subwoofer mount bracket
- High gloss metallic or fine textured matt finish

4 Specifications and Dimensions

4.3.3 Indigo Sub dimensions

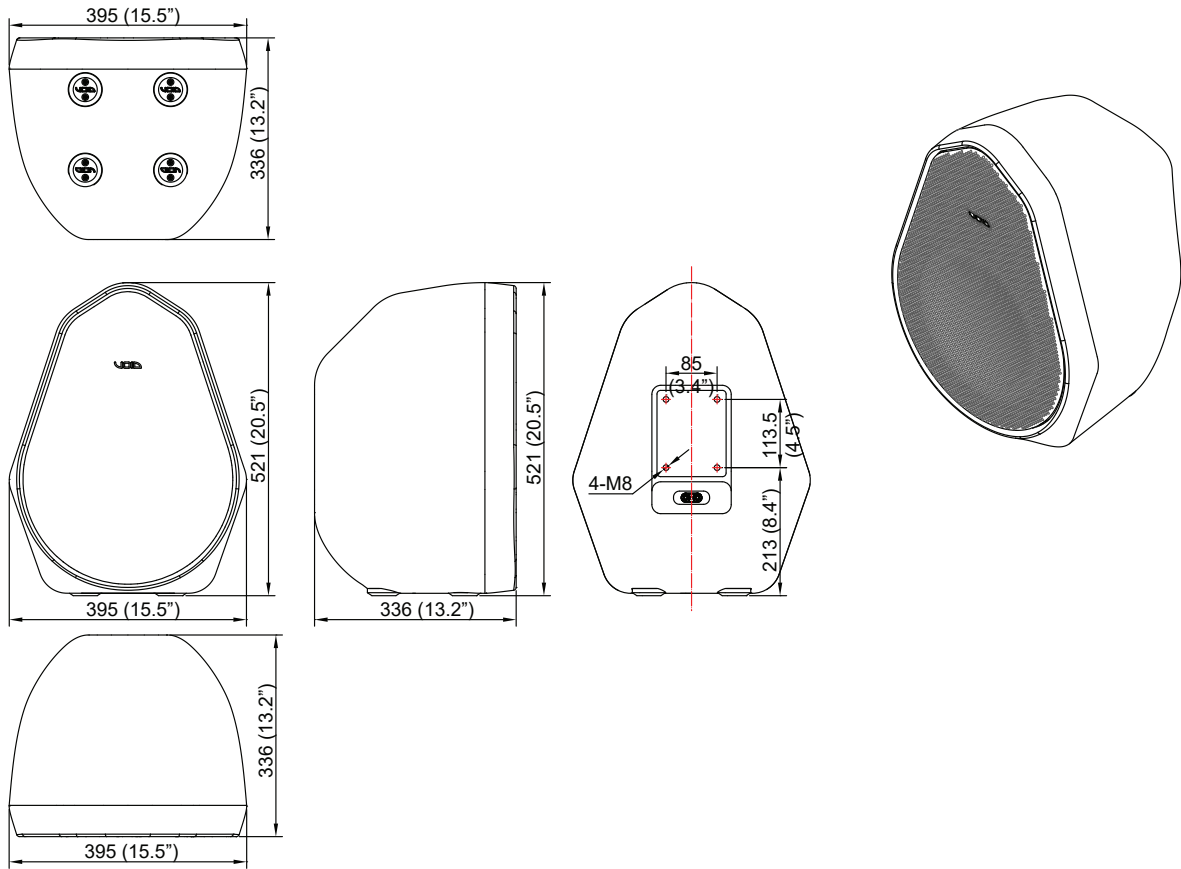

Figure 4.7: Dimensions

4.3.4 Indigo Sub impedance graph

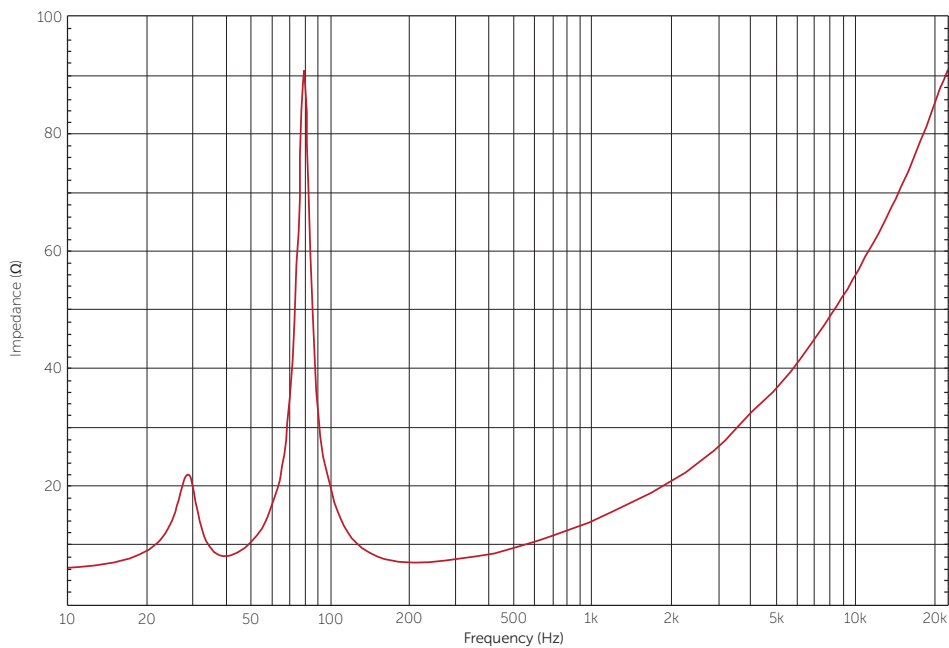

Figure 4.8: Impedance graph

5 Cable and Wiring

5.1 Electrical safety



To avoid electrical hazards please note the following:

- Do not access the inside of any electrical equipment. Refer servicing to Void-approved service agents

5.2 Cable considerations for fixed installations

We recommend specifying installation-grade Low Smoke Zero Halogen (LSZH) cables for permanent installations. The cables should use Oxygen Free Copper (OFC) of grade C11000 or above. Cables for permanent installations should be compliant with the following standards:

- IEC 60332.1 Fire retardancy of a single cable
- IEC 60332.3C Fire retardancy of bunched cables
- IEC 60754.1 Amount of Halogen Gas Emissions
- IEC 60754.2 Degree of acidity of released gases
- IEC 61034.2 Measurement of smoke density

We suggest using the following maximum copper cable lengths to keep level losses below 0.6 dB.

Metric mm ²	Imperial AWG	8 Ω load	4 Ω load	2 Ω load
2.50 mm ²	13 AWG	36 m	18 m	9 m
4.00 mm ²	11 AWG	60 m	30 m	15 m

5.3 Phoenix connector

Figure 6.1 shows the rear panel of a Indigo Series loudspeaker with the polarity of the Phoenix connector labelled. From left to right it is - and + for the feed to the drivers and the - and + for the link/out.

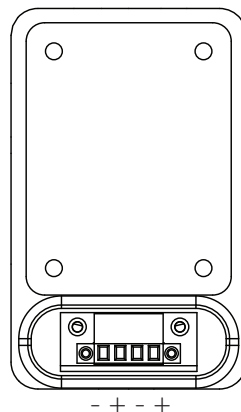

Figure 5.1: Phoenix connector

5 Cable and Wiring

5.4 Indigo 6s/Pro wiring diagram

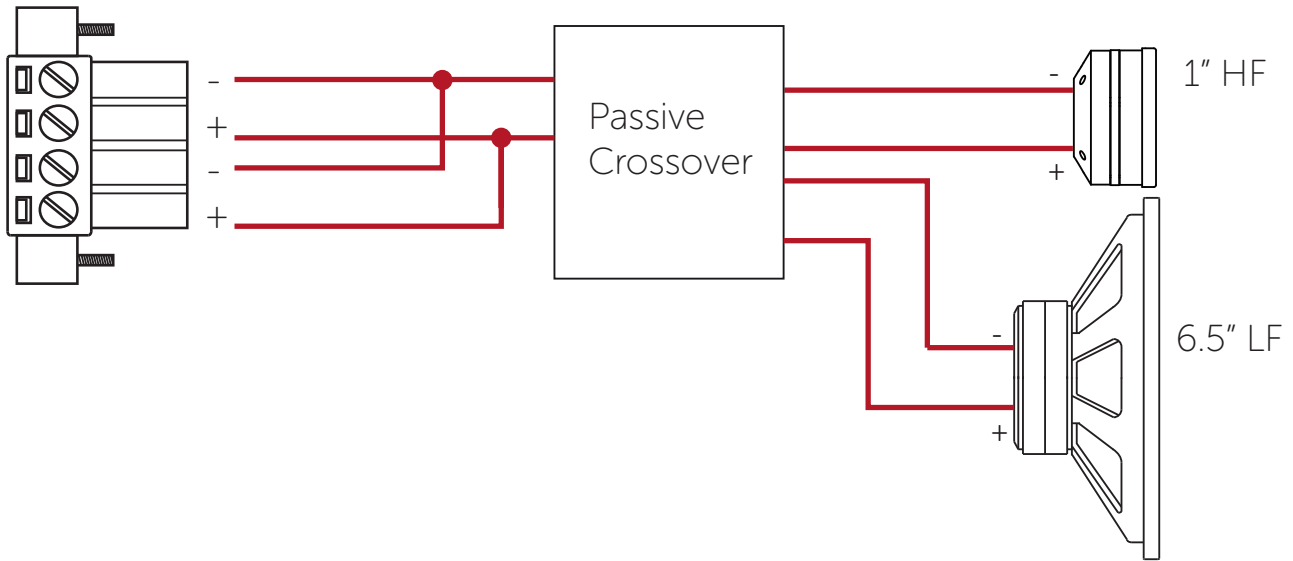

Figure 5.2: Indigo 6s/Pro wiring diagram

	Phoenix pins 1+/1-	Phoenix pins 2+/2-
In	LF (6.5") and HF (1")	Link/out

5.5 Indigo 6s/Pro Bias D1/Q1/Q2 Phoenix wiring

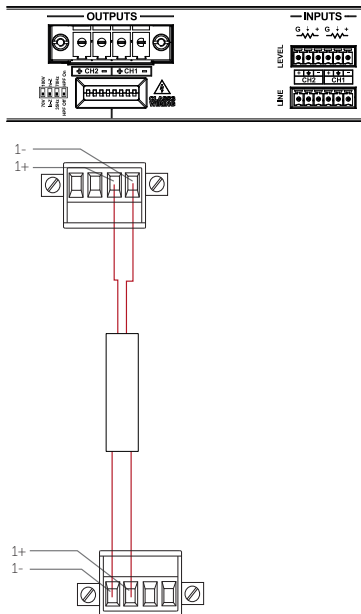

Figure 5.3: Bias D1 output connection

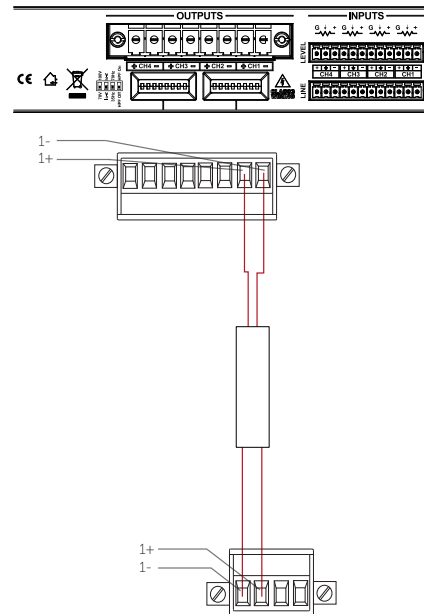

Figure 5.4: Bias Q1/Q2 output connection

Bias D1/Q1/Q2	Out 1
Output	LF (8") and HF (1")
Max parallel units	4 (2 Ω load to amplifier)

5 Cable and Wiring

5.6 Indigo 6s/Pro Bias Q3/Q5 speakON™ wiring

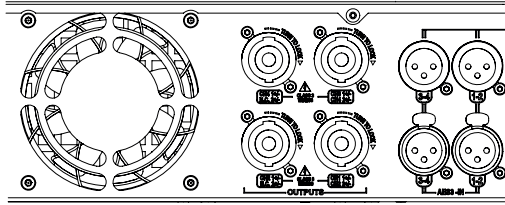

Figure 5.5: Bias Q3

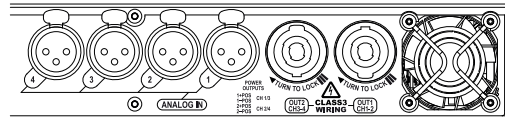

Figure 5.6: Bias Q5

Bias Q3/Q5	Out 1
Output	LF (8") and HF (1")
Max quantity per channel	4 (2 Ω load to amplifier)

5.7 Indigo Sub wiring diagram

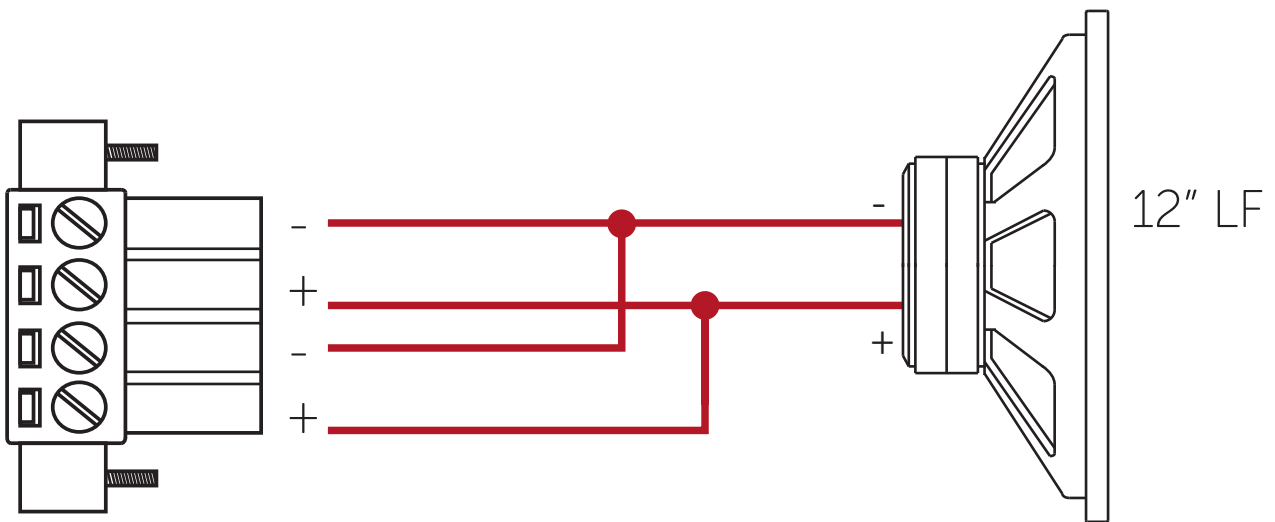

Figure 5.7: Indigo Sub wiring diagram

	Phoenix pins 1+/1-	Phoenix pins 2+/2-
In	LF (12")	Link/out

5.8 Indigo Sub Bias D1/Q1/Q2 Phoenix wiring

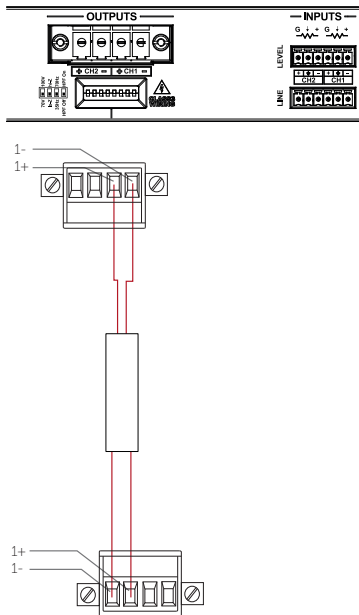

Figure 5.8: Bias D1

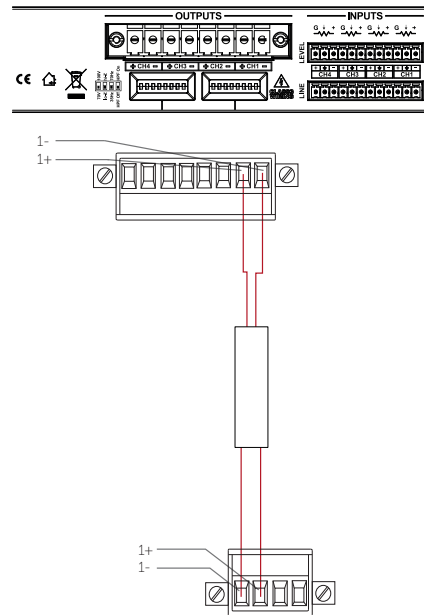

Figure 5.9: Bias Q1/Q2

Bias D1/Q1/Q2	Channel 1
Output	LF (12")
Max output	4 (2 Ω load to amplifier)

5.9 Indigo Sub Bias Q3/Q5 speakON™ wiring

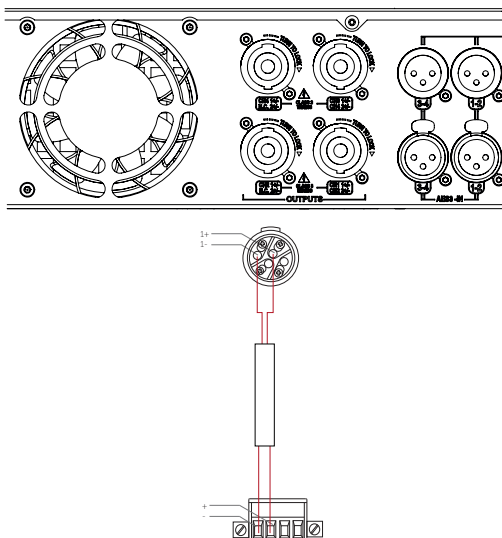

Figure 5.10: Bias Q3

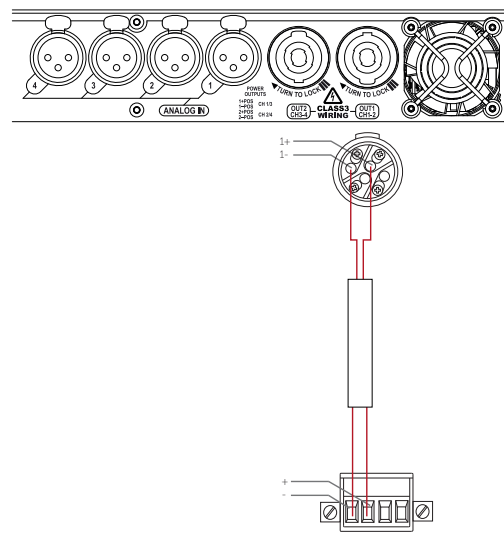

Figure 5.11: Bias Q5

Bias Q3/Q5	Channel 1
Output	Left LF (12")
Max quantity per channel	4 (2 Ω load to amplifier)

6 Mounting

Tools required

- 19 mm ratchet spanner/wrench
- 6 mm Allen key

6.1 Installation safety



To avoid mechanical hazards, please note the following:

- Safety regulations vary in different regions. Full compliance with those regulations must be your priority
- Installations must only be undertaken by fully qualified and experienced engineers/technicians who understand local regulations
- This may include consulting a structural engineer before installation of wall brackets
- Remember that all personnel have a duty of care to themselves, to their assistants, to the venue staff and to the public
- Before lifting any part of the system above head height, check the whole rig for loose tools or other items that may fall and cause injury
- Do not use a telephone (even if hands-free) whilst installing. Always concentrate fully on the installation operation
- Do not install equipment that is worn, damaged, corroded, mishandled or overstressed in any way
- Use only Void-approved mounting equipment and accessories
- Secondary safeties should be provided in all instances where cabinets are flying or fixing overhead and should conform to local regulations

6.2 Indigo 6s Wall Mounting

Part required:

4 mm Allen key

Indigo 6s Wall Bracket	White - IT1120 (supplied)
	Black - IT1119 (supplied)

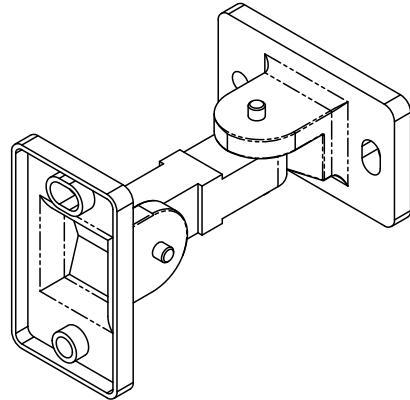

Figure 6.1: Indigo 6s bracket

Step 1:
Remove both M6 bolts.

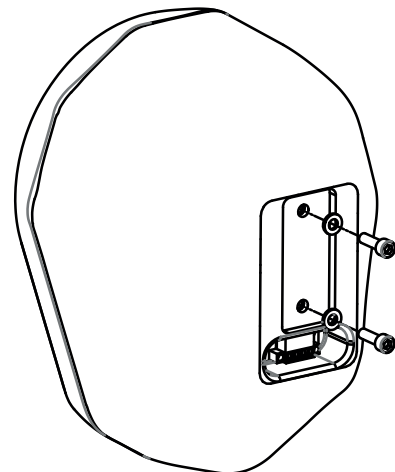

Figure 6.2: Bolt removal

Step 2:
Line up the bracket and fix both M6 bolts.

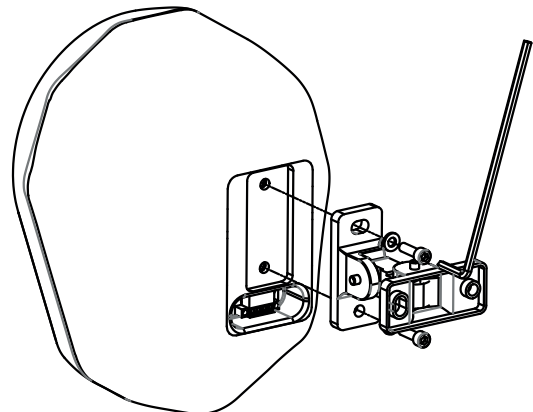

Figure 6.3: Bracket fixing

6.2 Indigo 6s Wall Mounting

Step 3:
Adjust the bracket to the required orientation using the bolts and the bracket assembly.

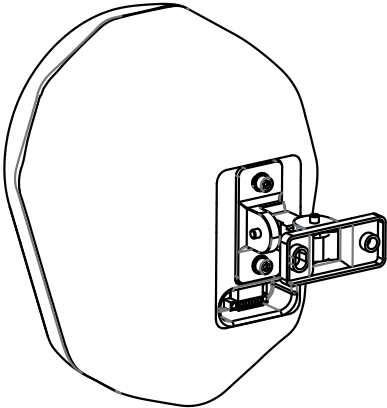

Figure 6.4: Bolt removal

The Indigo 6s bracket is capable of both wall and ceiling mounting as shown in figures 6.5a and 6.5b.

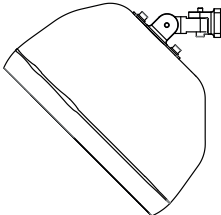

Figure 6.5a: Wall mounting

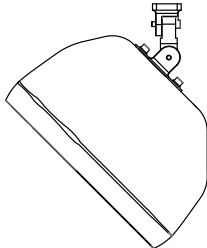

Figure 6.5b: Ceiling mounting

6.3 Indigo Sub and 6 Pro Mounting

Part required:

- 4 mm Allen key
- 5 mm Allen key

Indigo System Bracket	White - IT1118
	Black - IT1117

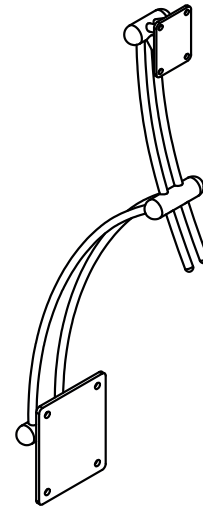

Figure 6.6: Indigo Sub bracket

Step 1:
Site the Indigo Sub in the desired location and remove all four M8 bolts from the rear.

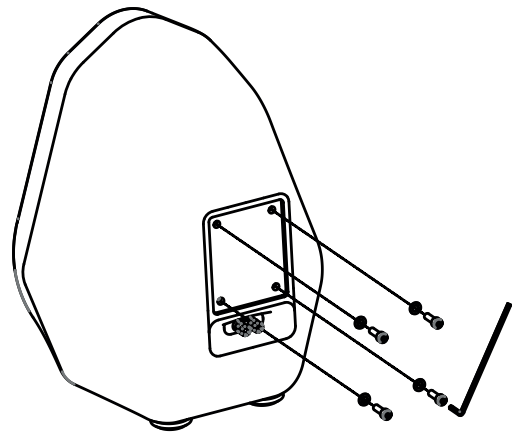

Figure 6.7: Bolt removal

Step 2:
Line up the bracket and fix all four M8 bolts.

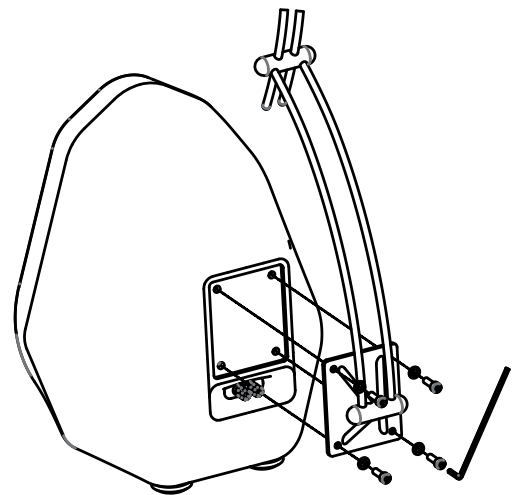

Figure 6.8: Bracket fixing to Indigo Sub

6.3 Indigo Sub and 6 Pro Mounting

Step 3:
Remove all four M6 bolts from the rear of the Indigo 6 Pro.

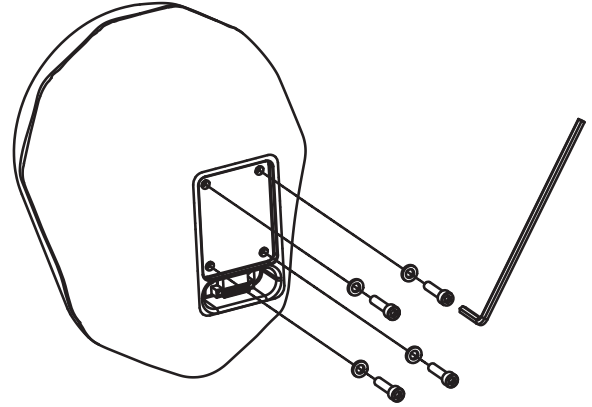

Figure 6.9: Bolt removal

Step 4:
Line up the Indigo 6 Pro with the Indigo Sub bracket and reattach all four M6 bolts.

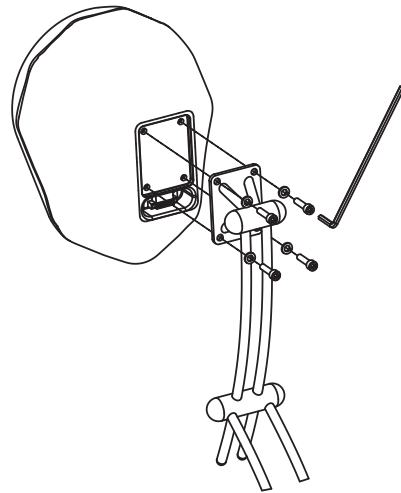

Figure 6.10: Indigo 6 Pro mounting

Step 5:
Ensure all bolts are firmly tightened.

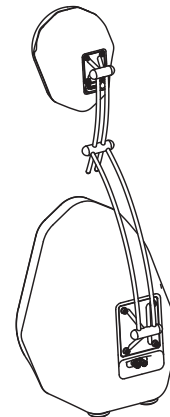

Figure 6.11: Final tightening

6.4 Indigo 6 Pro Wall Mounting

Part required:

- 4 mm Allen key
- 10 mm spanner/wrench

Indigo 6 Pro Wall Bracket	White - IT2631
	Black - IT2630

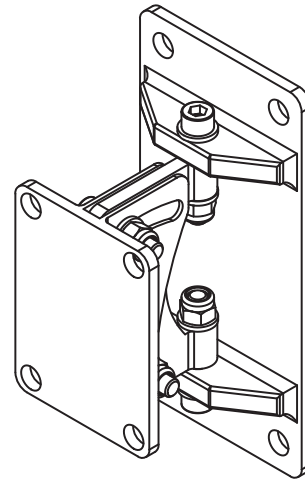

Figure 6.12: Indigo 6 Pro bracket

Step 1:
Remove both M6 bolts from the brackets assembly.

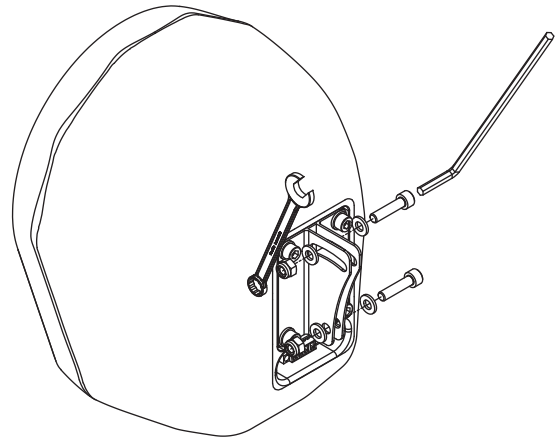

Figure 6.13: Bolt removal

Step 2:
Attach the rear of the bracket assembly to the wall.



All four bolts must be fitted when securing the bracket to the wall. Take care when mounting the bracket to the wall, making sure to use the correct fixing and that the wall can take the load, for example do not attach the bracket to a stud wall.

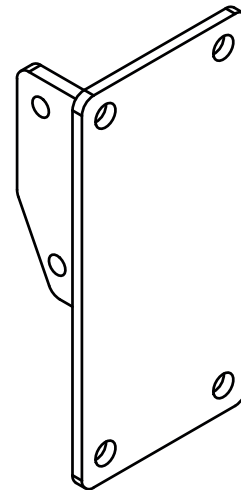

Figure 6.14: Rear bracket assembly

6.4 Indigo 6 Pro Wall Mounting

Step 3:
Line the rear bracket assembly with the fixings and reattach the bolts but do not tighten.

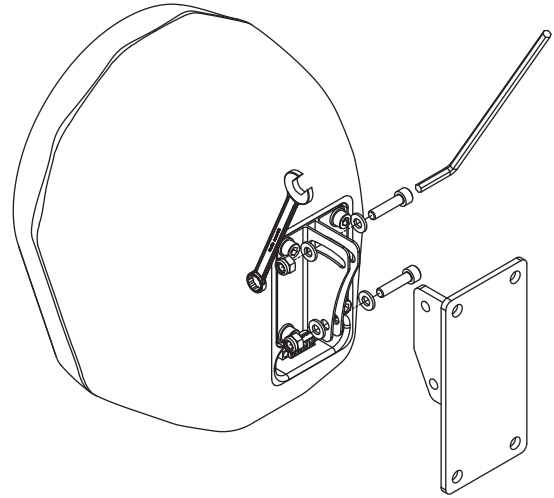

Figure 6.15: Mounting the loudspeaker

Step 4:
Adjust the vertical angle of the bracket and then tighten the bolts.

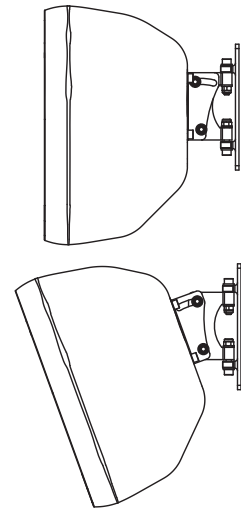

Figure 6.16: Adjusting the vertical angle

Step 5:
Adjust the horizontal angle of the bracket and then tighten the bolts.

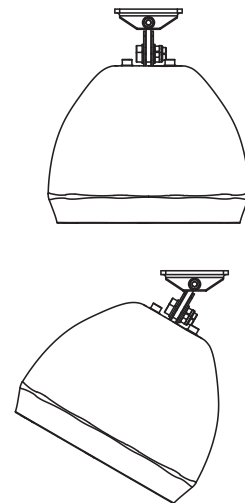

Figure 6.17: Adjusting the horizontal angle

7 Service

Void Indigo series loudspeakers should only be serviced by a fully trained technician.



No user serviceable parts inside. Refer servicing to your dealer.

7.1 Return authorisation

Before returning your faulty product for repair, please remember to get an R.A.N. (Return Authorisation Number) from the Void dealer who supplied the system to you. Your dealer will handle the necessary paperwork and repair. Failure to go through this return authorisation procedure could delay the repair of your product.

Note that your dealer will need to see a copy of your sales receipt as proof of purchase so please have this to hand when applying for return authorisation.

7.2 Shipping and packing considerations

- When sending a Void Indigo series loudspeaker to an authorised service centre, please write a detailed description of the fault and list any other equipment used in conjunction with the faulty product
- Accessories will not be required. Do not send the instruction manual, cables or any other hardware unless your dealer asks you to
- Pack your unit in the original factory packaging if possible. Include a note of the fault description with the product. Do not send it separately
- Ensure safe transportation of your unit to the authorised service centre.

8 Appendix

Indigo 6 Pro architectural specification

The loudspeaker shall be a passive two-way system consisting of one high power 6.5" (125 mm) direct radiating, reflex loaded, low frequency (LF) transducer and 1" (25 mm) diameter co-axially-mounted neodymium high frequency (HF) compression driver transducer mounted in a fibreglass enclosure with smooth cellulose finish.

The co-axial transducer shall be constructed on a cast aluminium frame with the low frequency transducer consisting of a polycarbonate LF cone with its dust cap removed with a 25.4 mm (1.5") voice coil, wound with copper wire on a high quality voice coil former, for high power handling and long-term reliability. The high frequency transducer shall be bolted through the rear of the magnet structure belonging to the LF transducer to form a co-axial drive unit. The sound will project through a machined waveguide that exits in the centre of the low frequency transducer to use the 166 mm (6.5") baffle diameter to achieve pattern control and low distortion.

Performance specifications for a typical production unit shall be as follows: the usable on-axis bandwidth shall be 68 Hz to 21 kHz (± 3 dB) and shall average 90° directivity pattern for both horizontal and vertical axis (-6 dB down from on-axis level) from 1 kHz to 12 kHz. Maximum SPL shall be 118 dB peak measured at 1 m using IEC268-5 pink noise. Power handling shall be 200 W AES at a rated impedance of 8 Ω . Crossover point shall be at 2.2 kHz using a 4th order filter (24 dB per octave). The system shall be powered by its own dedicated power amplification module with DSP management.

The wiring connection shall be via a single removable, lockable wiring connector with four screw-down terminals (one pair for input and one pair for loop-out to another loudspeaker) to provide secure wiring and allow for pre-wiring of the connector before the installation. This connector should then screw lock to the enclosure to ensure secure attachment.

The enclosure shall be of a moulded fibreglass reinforced plastic construction with a smooth cellulose finish and shall include integral threaded inserts for the fitment of wall and ceiling mounting hardware of any RAL colour with external dimensions of (W) 273 mm x (H) 209 mm x (D) 163 mm (10.7" x 8.2" x 6.4"). Weight shall be 5.2 kg (11.5 lbs).

The loudspeaker shall be the Void Acoustics Indigo 6 Pro.

8 Appendix

Indigo 6s architectural specification

The loudspeaker shall be a passive two-way system consisting of one high power 6.5" (125 mm), direct radiating, reflex loaded, low frequency (LF) transducer and 1" (25 mm) diameter soft dome tweeter high frequency (HF) transducer mounted in a fibreglass enclosure with a smooth cellulose finish.

The low frequency (LF) transducer shall be constructed on a cast aluminium frame with treated paper cone and a 25.4 mm (1.5") voice coil, wound with copper wire on a high quality voice coil former, for high power handling and long-term reliability. The high frequency transducer shall be a soft dome tweeter and shall project it's sound through a high precision constant directivity waveguide to achieve pattern control and low distortion.

Performance specifications for a typical production unit shall be as follows: the usable on-axis bandwidth shall be 70 Hz to 23 kHz (± 3 dB) and shall average 90° directivity pattern for both horizontal and vertical axis (-6 dB down from on-axis level) from 1 kHz to 12 kHz; and a maximum SPL of 111 dB peak measured at 1 m using IEC268-5 pink noise. Power handling shall be 80 W AES at a rated impedance of 8 Ω ; crossover point at 3.2 kHz using a 4th order filter (24 dB per octave). The system shall be powered by its own dedicated power amplification module with DSP management.

The wiring connection shall be via a single removable, lockable wiring connector with four screw-down terminals (one pair for input and one pair for loop-out to another loudspeaker) to provide secure wiring and allow for pre-wiring of the connector before the installation. This connector should then screw lock to the enclosure to ensure secure attachment.

The enclosure shall be of a moulded fibreglass reinforced plastic construction with a smooth cellulose finish and shall include integral threaded inserts for the fitment of wall and ceiling mounting hardware of any RAL colour with external dimensions of (H) 273 mm x (W) 209 mm x (D) 163 mm (10.7" x 8.2" x 6.4"). Weight shall be 2.2 kg (4.9 lbs).

The loudspeaker shall be the Void Acoustics Indigo 6s.

8 Appendix

Indigo Sub architectural specification

The loudspeaker shall be an active system consisting of one high power 12" (304.8 mm), direct radiating, reflex loaded, low frequency (LF) transducer mounted in a fibreglass enclosure with smooth cellulose finish.

The low frequency (LF) transducer shall be constructed on a cast aluminium frame with treated paper cone and a 101.6 mm (4") voice coil, wound with copper wire on a high quality voice coil former, for high power handling and long-term reliability.

Performance specifications for a typical production unit shall be as follows: the usable on-axis bandwidth shall be 40 Hz to 160 kHz (± 3 dB) and shall have a maximum SPL of 123 dB peak measured at 1 m using IEC268-5 pink noise. Power handling shall be 600 W AES at a rated impedance of 8 Ω . Pressure sensitivity shall be 92 dB measured at 1W/1m. The system shall be powered by its own dedicated power amplification module with DSP management.

The wiring connection shall be via a single removable, lockable wiring connector with four screw-down terminals (one pair for input and one pair for loop-out to another loudspeaker) to provide secure wiring and allow for pre-wiring of the connector before the installation. This connector should then screw lock to the enclosure to ensure secure attachment.

The enclosure shall be of a moulded fibreglass reinforced plastic construction with a smooth cellulose finish and shall include integral threaded inserts for the fitment of wall and ceiling mounting hardware of any RAL colour. External dimensions shall be (H) 521 mm x (W) 395 mm x (D) 336 mm (20.5" x 15.5" x 13.2"). Weight shall be 21 kg (46.3 lbs).

The loudspeaker shall be the Void Acoustics Indigo Sub.

NORTH AMERICA

Void Acoustics North America

Call: +1 630 686 6616

Email: sales.usa@voidacoustics.com

HEAD OFFICE

Void Acoustics Research Ltd,
Unit 15, Dawkins Road Industrial Estate,
Poole, Dorset,
BH15 4JY
United Kingdom

Call: +44(0) 1202 666006

Email: info@voidacoustics.com



Hear. Feel. Connect.

voidacoustics.com