



Hear. Feel. Connect.

voidacoustics.com



Venu 208i

Unobtrusive form, bold performance

USER GUIDE V1.0

©2023 Void Acoustics Research Ltd.

This user guide is subject to change without notice.
For the latest online version, visit: www.voidacoustics.com

Void Acoustics and the Void logo are registered trademarks of Void Acoustics Research Ltd. in the United Kingdom, USA and other countries; all other Void trademarks are the property of Void Acoustics Research Ltd.

Contents

1	Safety and Regulations	4
1.1	Important Safety Instructions	4
1.2	Limitations	4
1.3	EC Declaration of Conformity	4
1.4	UKCA Conformity	4
1.5	Warranty Statement	4
1.6	WEEE Directive	4
2	Unpacking and Checking	5
3	About	6
3.1	Welcome	6
3.2	Venu 208i Overview	6
3.3	Key Features	6
3.4	Venu 208i Specifications	7
3.5	Venu 208i Dimensions	8
4	Cable and Wiring	9
4.1	Electrical Safety	9
4.2	Cable Considerations for Fixed Installations	9
4.3	Venu 208i Wiring	9
4.4	Input Connectors	10
4.5	Output Connectors	10
4.6	Fuse rating	11
5	Venu 208i DSP	12
5.1	Components	12
5.2	Factory Presets	13
5.3	Selecting Your Preset	13
5.4	LED Chart	13
5.5	Power Management	14
5.6	Software	15
5.7	Changing Network Setting	16
5.7.1	Network Troubleshooting	17
5.8	Processing Architecture	18
5.9	Internal Signal Path Polarity	19
6	Mounting	20
6.1	Installation Safety	20
6.1	Yoke Bracket	21
6.2	Wall Mounting	22
6.3	Ceiling Mounting	24
7	Service	26
7.1	Return Authorisation	26
7.2	Shipping and Packing Considerations	26
8	Appendix	27

1 Safety and Regulations

1.1 Important safety instructions



The lightning flash with an arrowhead symbol within an equilateral triangle is intended to alert the user to the presence of uninsulated "dangerous voltage" within the product's enclosure that may be of sufficient magnitude to constitute a risk of electric shock to persons.



The exclamation point within an equilateral triangle is intended to alert the user of the presence of important operating and maintenance (servicing) instructions in the literature accompanying the appliance.

Safety instructions - read this first

1. Read these instructions.
2. Keep these instructions.
3. Heed all warnings.
4. Follow all instructions.
5. Do not use this apparatus near water.
6. Clean only with a dry cloth.
7. Do not block any ventilation openings. Install in accordance with the manufacturer's instructions.
8. Do not install near any heat source such as radiators, heat registers, stoves, or other such apparatus that produce heat.
9. Do not defeat the safety purpose of the grounding-type plug. A grounding type plug has two blades and a third grounding prong. The third prong is provided for your safety. If the provided plug does not fit into your outlet, consult an electrician for replacement of the obsolete outlet.
10. Protect power cords from being walked on or pinched particularly at plugs, convenience receptacles, and the point where they exit the apparatus.
11. Only use attachments and accessories specified by Void Acoustics.
12. Only use with the cart, stand, tripod, bracket, or table specified by the manufacturer, or sold with the apparatus. When a cart is used, use caution when moving the cart/apparatus combination to avoid injury from tip-over.
13. Unplug the apparatus during lightning storms or when unused for long periods of time.
14. Refer all servicing to qualified service personnel. Servicing is required when the apparatus has been damaged in any way, such as when the power-supply cord or plug is damaged, liquid has been spilled or objects have fallen into the apparatus, the apparatus has been exposed to rain or moisture, does not operate normally, or has been dropped.
15. Since the mains power supply cord attachment plug is used to disconnect the device, the plug should always be easily accessible.
16. Void loudspeakers can produce sound levels capable of causing permanent hearing damage from prolonged exposure. The higher the sound level, the less exposure needed to cause such damage. Avoid prolonged exposure to the high sound levels from the loudspeaker.

1.2 Limitations

This guide is provided to help familiarise the user with the loudspeaker system and its accessories. It is not intended to provide comprehensive electrical, fire, mechanical and noise training and is not a substitute for industry-approved training. Nor does this guide absolve the user of their obligation to comply with all relevant safety legislation and codes of practice. While every care has been taken in creating this guide, safety is user-dependent and Void Acoustics Research Ltd cannot guarantee complete safety whenever the system is rigged and operated.

1.3 EC declaration of conformity

For EC Declaration of Conformity please go to:

www.voidacoustics.com/eu-declaration-loudspeakers

1.4 UKCA marking

For details of the UKCA marking go to:

www.voidacoustics.com/uk-declaration-loudspeakers

1.5 Warranty statement

For warranty statement go to:

<https://voidacoustics.com/terms-conditions/>

1.6 WEEE directive

If the time arises to throw away your product, please recycle all the components possible.



This symbol indicates that when the end-user wishes to discard this product, it must be sent to separate collection facilities for recovery and recycling. By separating this product from other household-type waste, the volume of waste sent to incinerators or land-fills will be reduced and natural resources will thus be conserved.

The Waste Electrical and Electronic Equipment Directive (WEEE Directive) aims to minimise the impact of electrical and electronic goods on the environment. Void Acoustics Research Ltd complies with the Directive 2002/96/EC and 2003/108/EC of the European Parliament on waste electrical and electronic equipment (WEEE) in order to reduce the amount of WEEE that is being disposed of in land-fill sites. All of our products are marked with the WEEE symbol; this indicates that this product must NOT be disposed of with other waste. Instead it is the user's responsibility to dispose of their waste electrical and electronic equipment by handing it over to an approved reprocessor, or by returning it to Void Acoustics Research Ltd for reprocessing. For more information about where you can send your waste equipment for recycling, please contact Void Acoustics Research Ltd or one of your local distributors.

2 Unpacking and Checking

All Void Acoustics products are carefully manufactured and thoroughly tested before being despatched. Your dealer will ensure that your Void products are in pristine condition before being forwarded to you but mistakes and accidents can happen.

Before signing for your delivery:

- Inspect your shipment for any signs of contamination, abuse or transit damage as soon as you receive it
- Check your Void Acoustics delivery fully against your order
- If your shipment is incomplete or any of its contents are found to be damaged; inform the shipping company and inform your dealer.

When you are removing your Venu 208i loudspeaker from its original packaging:

- Venu 208i loudspeakers come double boxed and each box is stapled shut; take care when unboxing and removing the staples to avoid injury or damage to the loudspeaker
- If you need to place the Venu loudspeaker on a flat surface ensure you use a lint free product to protect the finish
- When you have removed the Venu 208i loudspeaker from the packaging inspect it to ensure there is no damage and keep all original packaging in case it needs to be returned for any reason.

See section 1.5 for warranty conditions and see section 7 if your product needs servicing.

3 About

3.1 Welcome

Many thanks for purchasing this Void Acoustics Venu 208i loudspeaker. We truly appreciate your support. At Void, we design, manufacture and distribute advanced professional audio systems for the installed and live sound market sectors. Like all Void products, our highly skilled and experienced engineers have successfully combined pioneering technologies with groundbreaking design aesthetics, to bring you superior sound quality and visual innovation. In buying this product, you are now part of the Void family and we hope using it brings you years of satisfaction. This guide will help you both use this product safely and ensure it performs to its full capability.

3.2 Venu 208i overview

The Venu 208i is an ultra-compact, self-powered, double 8" subwoofer capable of powering up to four mid-high enclosures, including Cyclone 4, Cyclone 55 and Indigo 6 from its built-in dual 150 Watt power modules. Providing a frequency response of 42 Hz – 120 kHz \pm 3 dB and a continuous output of 119 dB, peaking at 125 dB, the Venu 208i will provide flawless bass to any commercial/residential applications

Incorporating all the key elements of the Venu V2 range in a compact and stylish, enclosure, Venu 208i also benefits from built in DSP for loudspeaker control and advanced signal processing capabilities that can be accessed via the rear ethernet port.

3.3 Key features

- 600 W amplifier module (300 W + 2 x 150 W)
- Built-in DSP
- Parallel tuned 6th order bandpass dual 8" low frequency loudspeaker
- Tough high excursion transducers
- Yoke bracket and type 75 plate positions for wall or ceiling mounting
- Sturdy enclosure made entirely from multi-laminate birch plywood

3 About

3.4 Venu 208i specifications

Bass frequency range	42 Hz - 120 Hz \pm 3 dB
Input	2 x combo XLR
Maximum output	119 dB cont, 125 dB peak
Driver configuration	2 x 8" LF
Height	203 mm (8")
Width	600 mm (23.6")
Depth	475 mm (18.7")
Weight	21 kg (46.3 lbs)
Enclosure	15 mm birch plywood
Finish	Textured Warnex
Grille	Powder-coated perforated steel - foam filter
Output	1 x Phoenix connector
2-channel output mode	
4 Ω / Ch (balanced)	150 W
8 Ω / Ch (balanced)	75 W
Max output voltage	35 V _{peak}
Max output current	10 A _{peak}
Nominal power requirement	AC 100 V - 240 V, 50/60 Hz
Consumption	
Standby	< 0.5 W
Idle	< 10 W
1/4 of max output power @ 4 Ω	150 W
Amplifier and DSP features	
Crosstalk separation (1 kHz)	Typically . 70 dB
Input sensitivity	3 V _{RMS} / 11.7 dBu
Input impedance	13 k Ω balanced
THD+N / DIM100 (from 0.1 W to 1/2 Power)	< 0.1% (typically <0.05%)

3 About

3.5 Venu 208i dimensions

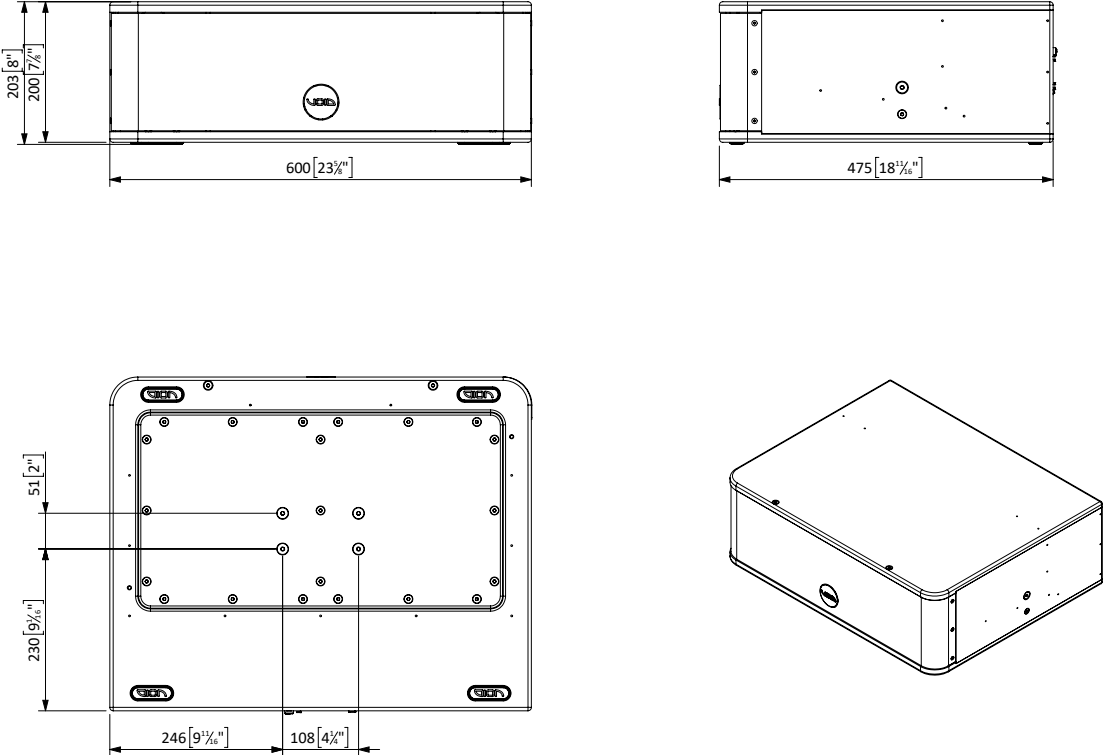

Figure 3.1: Dimensions

4 Cable and Wiring

4.1 Electrical safety

To avoid electrical hazards please note the following:



- Do not access the inside of any electrical equipment. Refer servicing to Void-approved service agents.

4.2 Cable considerations for fixed installations

We recommend specifying installation-grade Low Smoke Zero Halogen (LSZH) cables for permanent installations. The cables should use Oxygen Free Copper (OFC) of grade C11000 or above. Cables for permanent installations should be compliant with the following standards:

- IEC 60332.1 Fire retardancy of a single cable
- IEC 60332.3C Fire retardancy of bunched cables
- IEC 60754.1 Amount of Halogen Gas Emissions
- IEC 60754.2 Degree of acidity of released gases
- IEC 61034.2 Measurement of smoke density.

4.3 Venu 208i wiring

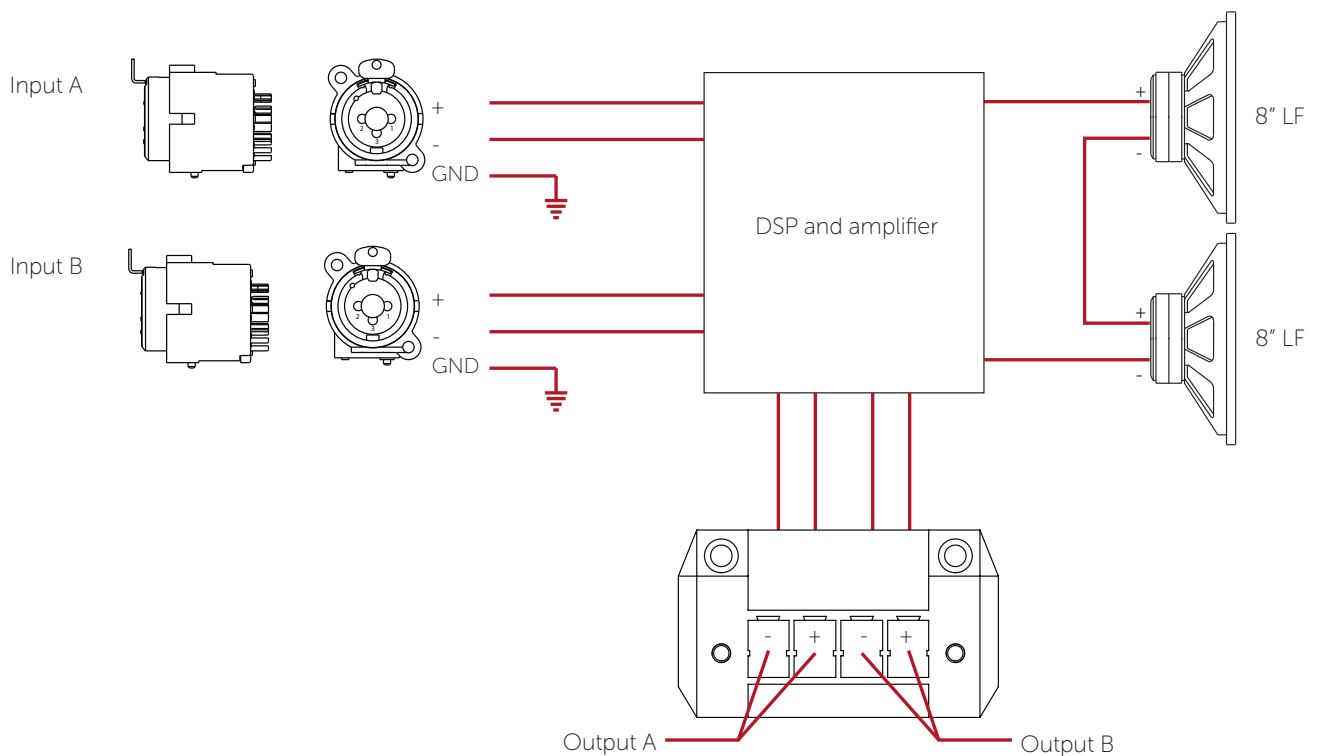

Figure 4.1: Venu 208i wiring diagram

4 Cable and Wiring

4.4 Input connectors

Analogue input XLR-M pinout

Pin 1	GND
Pin 2	Hot +
Pin 3	Cold -

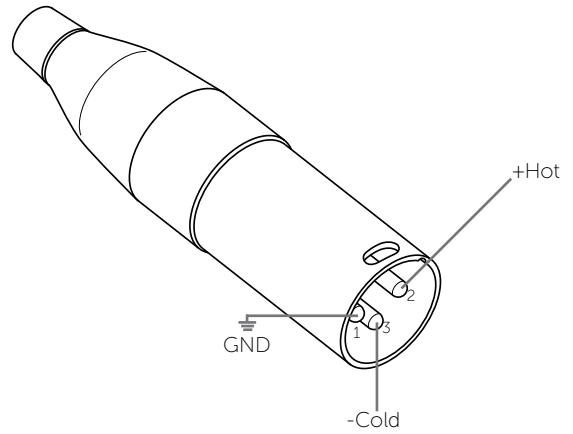

Figure 4.2: XLR-M diagram

Analogue input TRS Jack pinout

Tip	Hot +
Ring	Cold -
Sleeve	GND

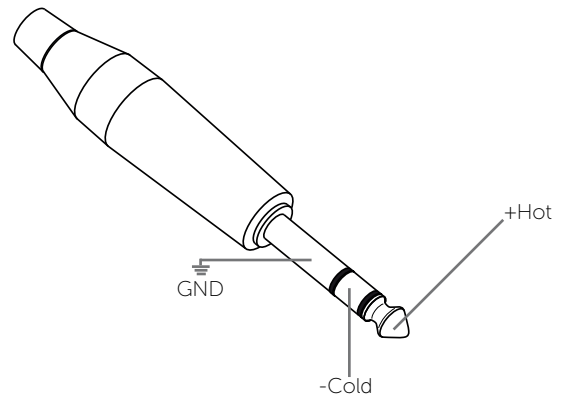

Figure 4.3: TRS Jack diagram

4.5 Output connectors

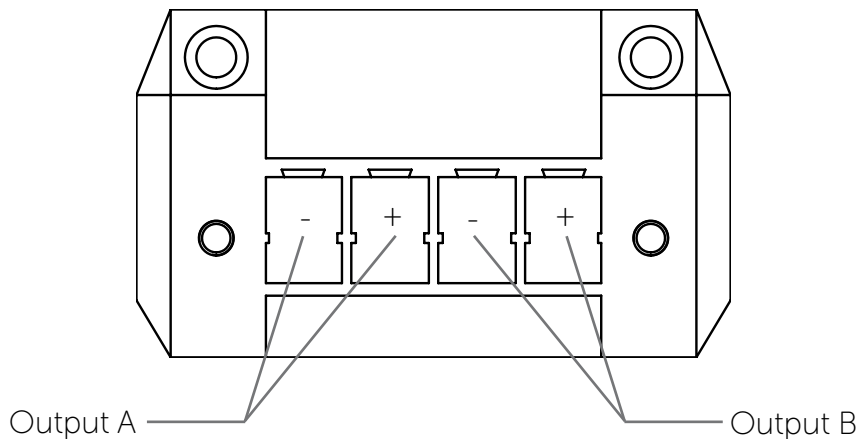

Figure 4.4: Output phoenix connector

4 Cable and Wiring

4.6 Fuse rating

All Venu 208i have two voltage options, 230 V and 115 V, depending on the orientation of the fuse holder. To change the voltage follow these steps.



Step 1: Remove the fuse holder cover by using a flat head screwdriver as shown.



Step 2: Remove the fuse holder by using a flat head screwdriver as shown.



Step 3: Remove the fuse holder and rotate so that the voltage rating you require is oriented to the left.



Step 4: Insert the fuse holder ensuring it is fully engaged.



Step 5: Push the fuse holder cover in so that it is completely sealed.

5 Venu 208i DSP

5.1 Components

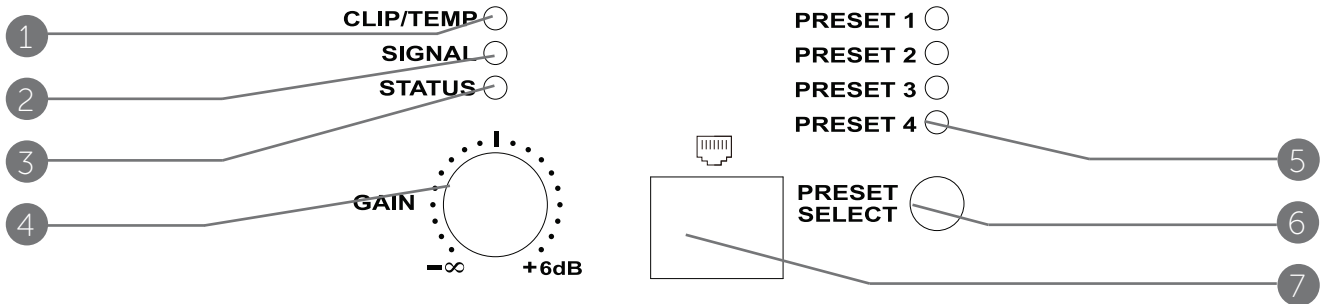

Figure 5.1: LED panel

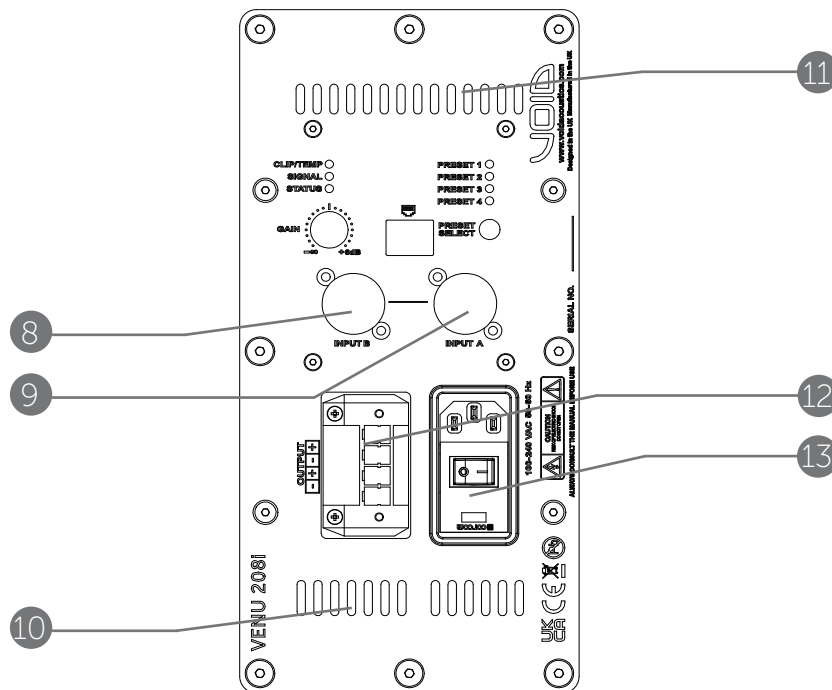

Figure 5.2: Rear panel

- | | |
|--|--|
| <ul style="list-style-type: none"> 1. Signal clipping LED 2. Signal presence/limiting LED 3. Status LED 4. Volume potentiometer 5. Preset LEDs 6. Preset select 7. Ethernet connector | <ul style="list-style-type: none"> 8. Combi Jack - XLR input signal connector input B 9. Combi Jack - XLR input signal connector input A 10. Fan Inlet 11. Exhaust vent 12. Phoenix connector output 13. IEC C13 power input |
|--|--|

5 Venu 208i DSP

5.2 Factory presets

Factory presets for the Venu 208i are as follows:

Preset 1	Cyclone 4
Preset 2	Cyclone 55
Preset 3	Indigo 6s
Preset 4	Venu 6 V2

5.3 Selecting your preset

To change your Venu 208i preset:

1. Apply power to the amplifier
2. Wait 15 seconds for the amplifier to initialise
3. Press the preset button
4. The next selected preset light will begin flashing
5. When the preset LED stops flashing and becomes steady the amplifier is ready to use in that preset mode.

For alternative loudspeaker presets, please download the relevant files from the support documents tab found on <https://voidacoustics.com/resources-and-support>

5.4 LED chart

Clip/temp LED

Colour	Solid on	Action required
Off	Temperature OK, no clipping	No action required
Yellow	High amplifier temperature	Reduce system gain
Red	Output signal clipping	Reduce system gain

Signal LED

Colour	Solid on	Action required
Green	Input signal present, output not in limit	No action required
Yellow	Output limiter engaging	Reduce system gain
Red	Input signal clipping	Reduce input gain

Status LED

Colour	Solid ON
Off	System off
Green	System ready to play, auto standby mode disabled
Cyan	System ready to play, auto standby mode enabled
Blue	System in standby mode: no signal detected in the last 15 minutes

5 Venu 208i DSP

5.5 Power management

It is possible to implement a power saving strategy to reduce power consumption and heat build-up. By factory default, the power management feature is not active. Pressing and holding the Preset Select button for at least 3 seconds will toggle the power management. When active (Cyan Status LED), the Venu 208i will enter a low power operating mode after 15 minutes of no input signal (input level below -45 dBu). The DSP board will send a signal to the amplifier module turning off the output stages and enabling standby mode (Blue LED).

On detection of an input signal (input level above -45 dBu), the DSP board will automatically re-engage the amplifier module and exit standby mode.

5 Venu 208i DSP

5.6 Software

1. Download and install Armonia Plus from the support page on the Void Acoustics website. If not already installed download the Venu 208i model from the marketplace within Armonia Plus
2. Connect an ethernet cable from the Venu 208i to the PC or router
3. Open Armonia Plus and click on the cog wheel in the bottom right corner of the window. Ensure that the appropriate network interface is enabled under the Communication Manager tab

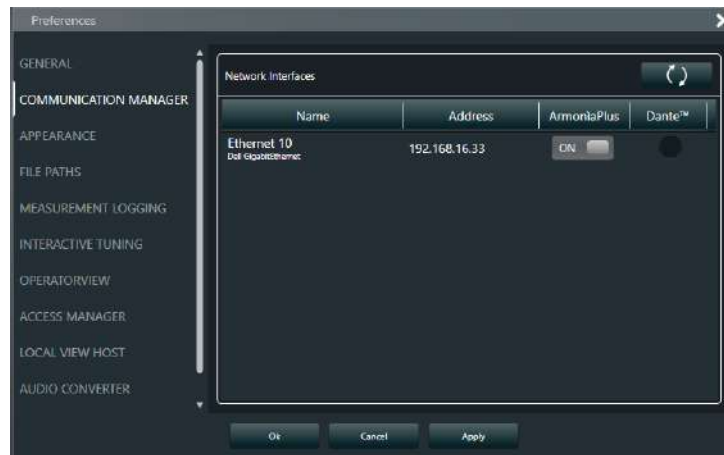

Figure 5.3: Armonia Plus communications manager

4. Click on Match under the design tab, then Discovery. Armonia Plus should now be able to detect the device.

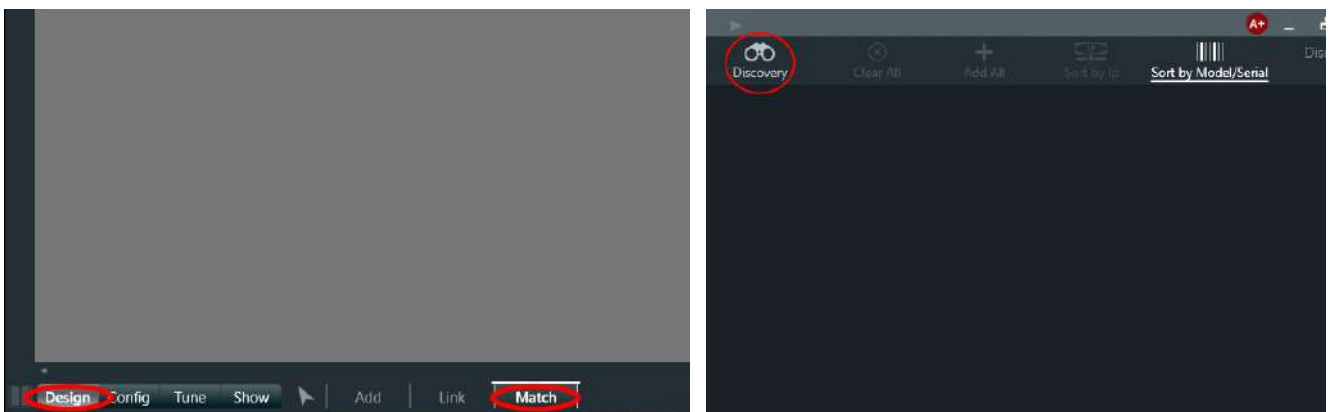

Figure 5.4: Armonia Plus tab selection

5. Click on the red Synchronisation button in the top right corner of the window. Turn Synchronisation on. You will now be able to add the device to the workspace and access the DSP.

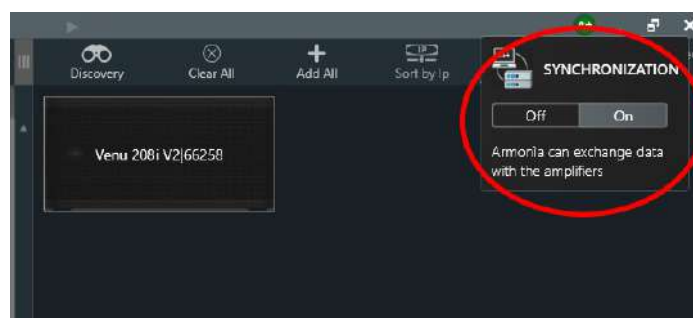

Figure 5.5: Synchronisation and DSP access

5 Venu 208i DSP

5.7 Changing network setting

Once added to the workspace, double click on the Venu 208i to access the processing options. The Network Settings section is available by clicking on the button under the Scheme window. Here you can view the current ethernet status and change address settings.

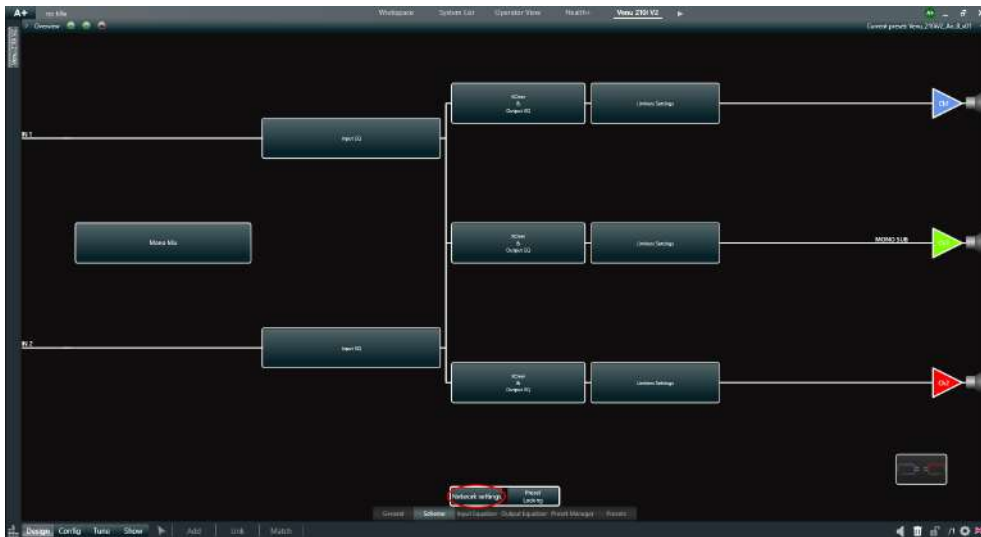

Figure 5.6: Scheme window

In order to set a static IP, click on Change Address Settings, choose Static as Addressing Mode and enter the chosen IP address. Be aware that changing these settings could break communication with the Venu 208i. Confirm the changes by clicking on Apply Settings. The new static IP will be applied immediately.

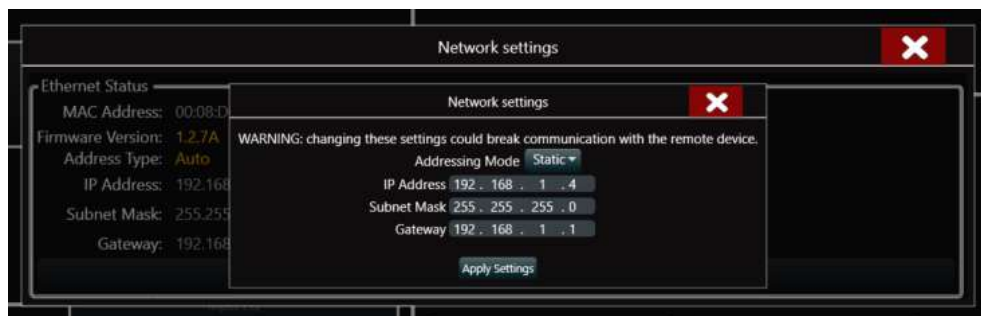

Figure 5.7: Network settings

5 Venu 208i DSP

5.7.1 Network troubleshooting

The Venu 208i cannot be discovered by Armonía Plus when it is set with a different subnet than the network card to which it's connected. In this case, after you have clicked on Discovery, Armonía Plus will report that a connected device has an incompatible IP address.

Hovering the mouse pointer above the alert message displayed at the bottom of the Match window will show the current device IP address. In order to discover the Venu 208i you will need to adjust the settings of the PC network card to be compatible with those of the product being connected to:

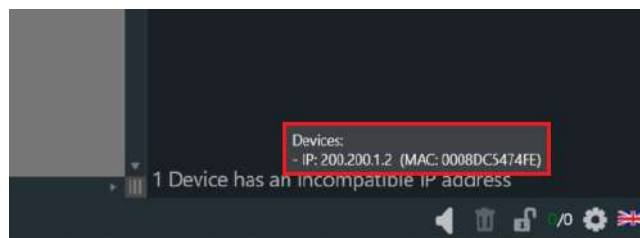

Figure 5.8: IP address warning

Go to Network Connection following this path: Control Panel \ Network and Internet \ Network Connections

Right click on the network card you are using and click on Properties. In the Networking tab, find the item Internet Protocol Version 4 (TCP/IPv4), select it and click on Properties. This will allow you to set a static IP address for the PC in the same range as the Venu 208i.

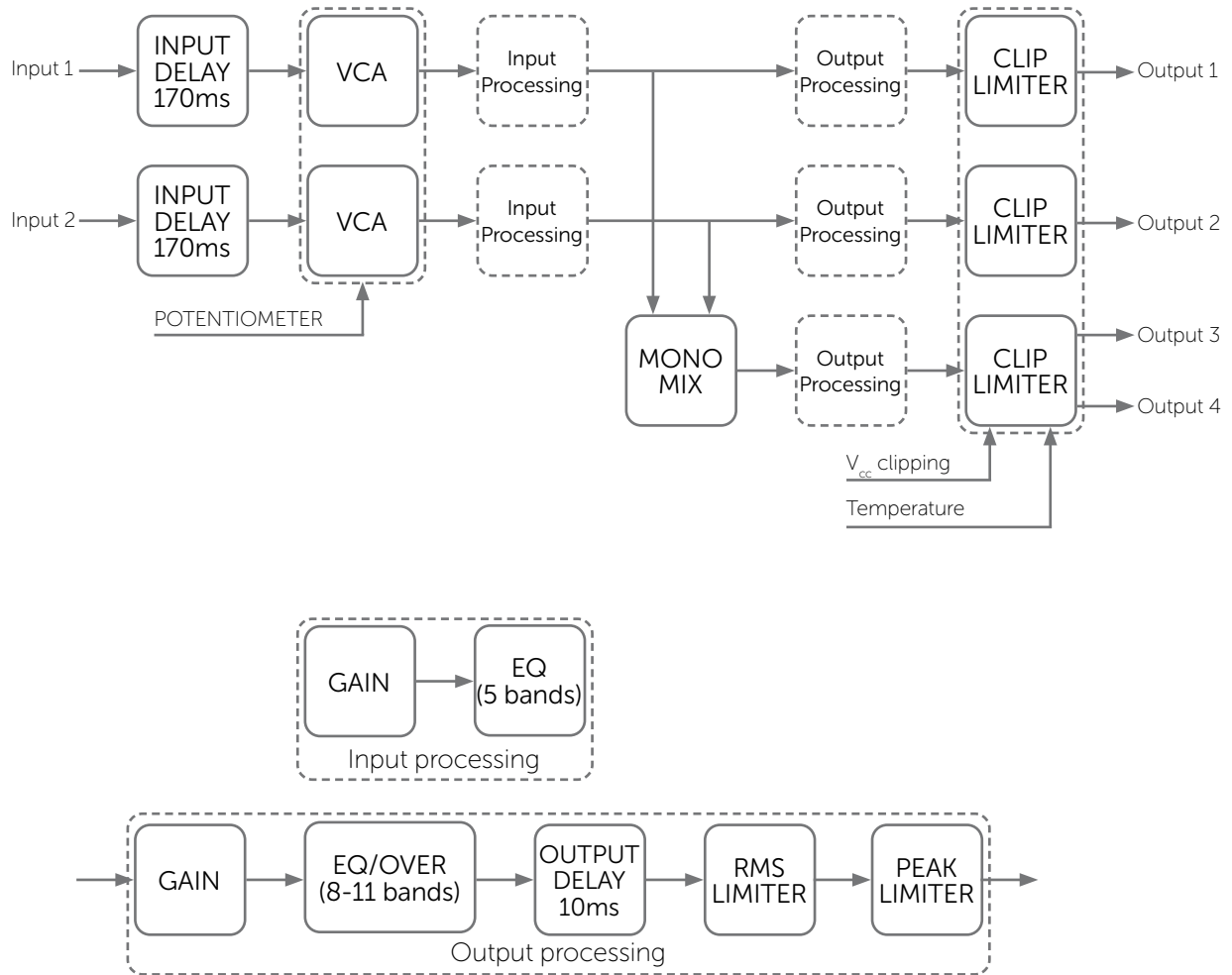

Figure 5.9: Internet Protocol Version 4 (TCP/IPv4) properties

In Armonía Plus, re-enable the network card with the new IP settings in the Communication Manager and follow the connection steps in Section 5.6. Once added to the workspace, you can change its IP configuration as outlined in Section 5.7, then re-establish the PC network card with the previous settings.

5 Venu 208i DSP

5.8 Processing architecture



5.9 Internal signal path polarity

In order to increase the power's supply energy storage efficiency, signals coming from channel pairs 1-2 are polarity reversed, one with respect to the other within the pair, when entering the amplifier. This ensures a symmetrical use of the voltage rails: if, for example, both channels' 1 and 2 input signals are going through a peak at the same time, channel 1's energy will come from the positive voltage rails while channel 2, whose polarity is reversed with respect to channel 1, will be fed energy from the negative voltage rails. In this manner, the power supply will work symmetrically, with one channel catered by the positive rails and the other by the symmetrical negative rails. Channel 2's signal will be polarity reversed once more to ensure that both channels output with the same polarity as their corresponding input signals.

For this reason it is very important not to invert the polarity of either channels before feeding them to the module. A double polarity inversion (the first by the user inserting the input signal and the other by the amplifier's internal circuitry) results in no inversion at all. If this were the case, both channels would be weighing on only one side (positive or negative) of the power supply's voltage rails. This would result in an inefficient use of the power supply's energy.

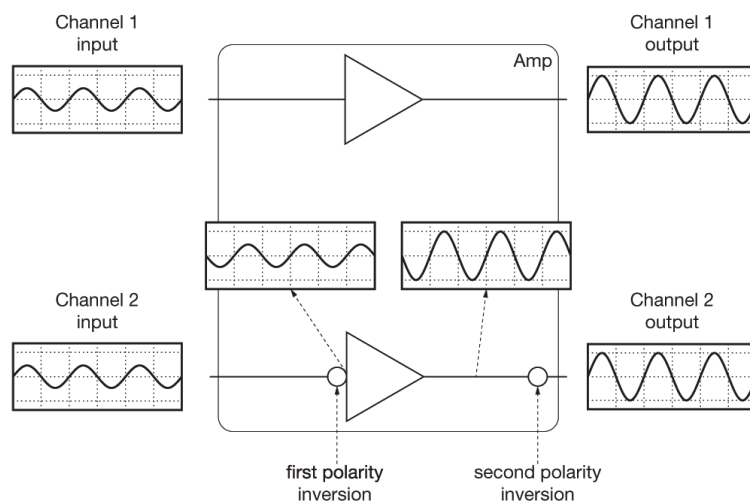

Figure 5.10: Internal signal path polarity with example input signal.
Both channels 1 and 2 are fed with the same sine signal.

6 Mounting

6.1 Installation safety

To avoid mechanical hazards, please note the following:



- Safety regulations vary in different regions. Full compliance with those regulations must be your priority
- Installations must only be undertaken by fully qualified and experienced engineers/technicians who understand local regulations
- This may include consulting a structural engineer before installation of wall brackets
- Remember that all personnel have a duty of care to themselves, to their assistants, to the venue staff and to the public
- Before lifting any part of the system above head height, check the whole rig for loose tools or other items that may fall and cause injury
- Do not use a telephone (even if hands-free) whilst installing. Always concentrate fully on the installation operation
- Do not install equipment that is worn, damaged, corroded, mishandled or overstressed in any way
- Use only Void-approved mounting equipment and accessories
- Secondary safeties should be provided in all instances where cabinets are flying or fixing overhead and should conform to local regulations

6.2 Yoke Bracket

Parts required:

Venu 208 Yoke Bracket	White - IT3216
	Black - IT3215



Note:
All bolts must be fitted when securing the bracket to the wall.

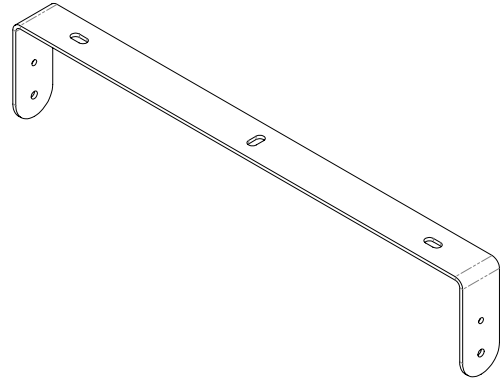

Figure 6.1: Venu 208 Yoke Bracket

Step 1:
Remove the M6 and M8 countersink bolts from the sides of the cabinet

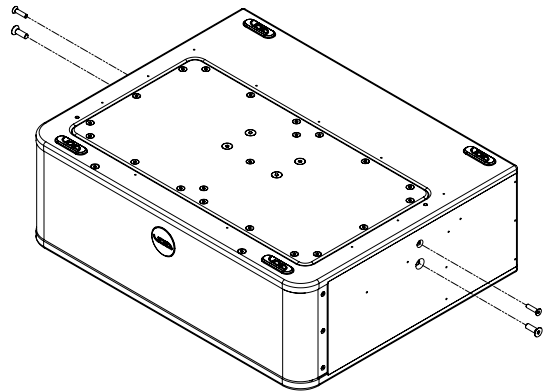

Figure 6.2: Bolt removal

Step 2:
With the yoke bracket fixed in position insert the M6 and M8 socket head bolts provided with the bracket.

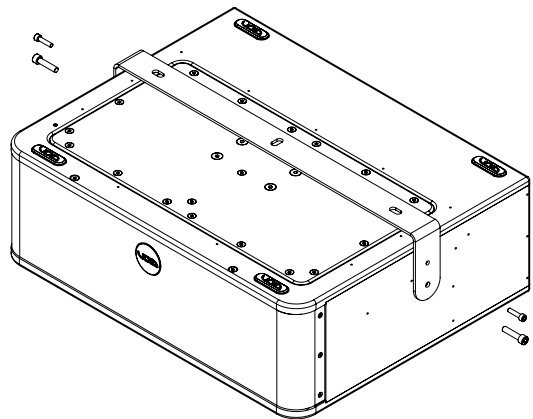

Figure 6.3: Attaching yoke bracket

6.3 Wall Mounting

Parts required:

T75 - Wall Bracket	White - IT1133
	Black - IT1132



Note:
All bolts must be fitted when securing the bracket to the wall.

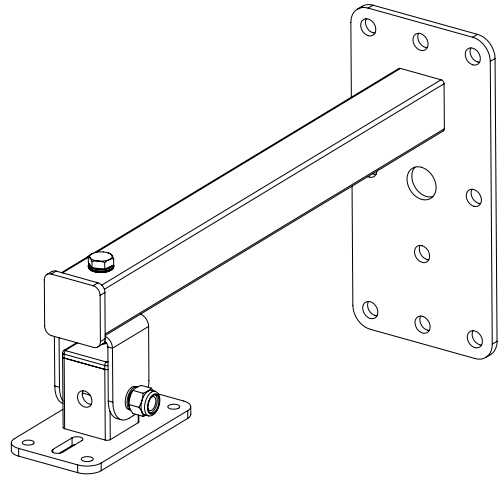

Figure 6.4: T75 Wall Bracket

Step 1:
Remove all four M8 countersink bolts from the bottom of the cabinet as shown.

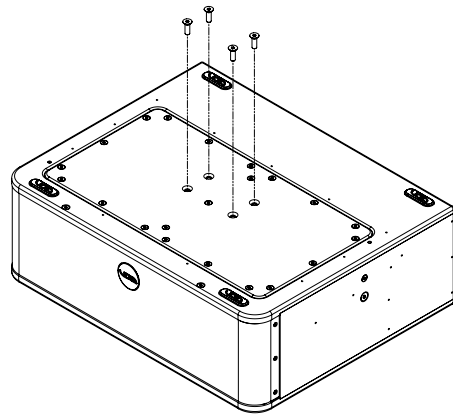

Figure 6.5: Bolt removal

Step 2:
Remove the type 75 plate from the bracket and fix it to the cabinet with M8 socket head bolts provided with the bracket.

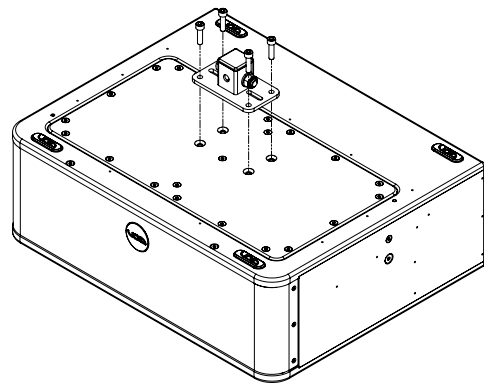

Figure 6.6: Type 75 plate attachment

6.3 Wall Mounting

Step 3:
With the wall bracket fixed in position fix the type 75 plate to the bracket with the M12 bolt.

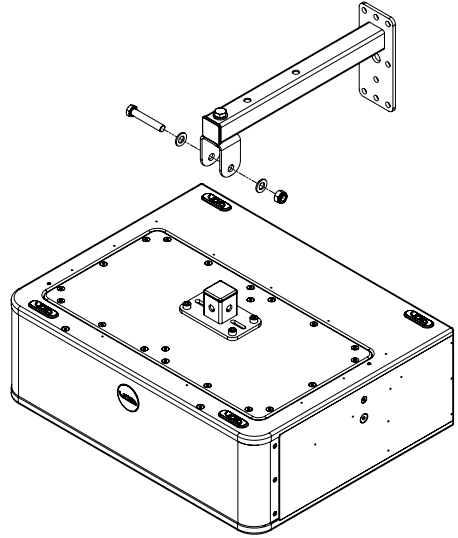

Figure 6.7: Wall bracket fixing

6.4 Ceiling Mounting

Parts required:

T75 - Ceiling Bracket (500 mm)	White - IT1905
	Black - IT1140
T75 - Ceiling Bracket (1000 mm)	White - IT3218
	Black - IT3217
T75 - Ceiling Bracket (1500 mm)	Black - IT3688



Note:

All eight bolts must be fitted when securing the bracket. Pole can be cut to length on site to accommodate installation requirements.

Step 1:
Remove all four M8 countersink bolts from the bottom of the cabinet as shown.

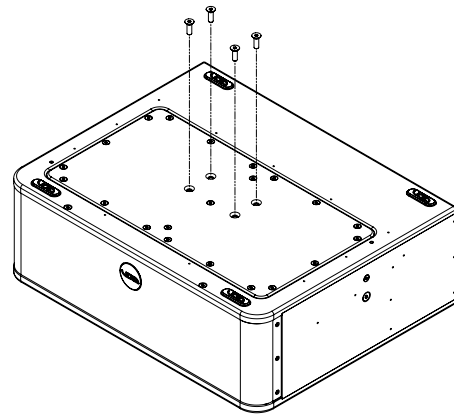

Figure 6.9: Bolt removal

Step 2:
Remove the type 75 plate from the bracket and fix it to the cabinet with M8 socket head bolts provided with the bracket.

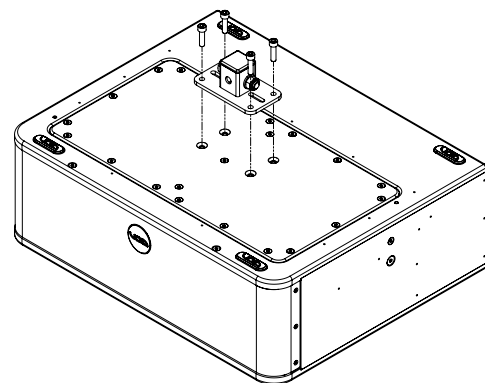

Figure 6.10: Type 75 plate attachment

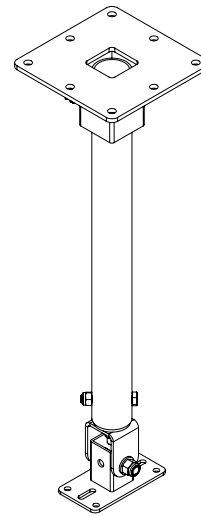

Figure 6.8: T75 Ceiling Bracket

6.4 Ceiling Mounting

Step 3:
With the ceiling bracket fixed in position fix the type 75 plate to the bracket with the M12 bolt.

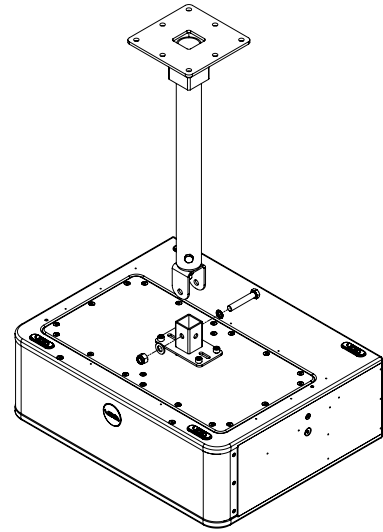

Figure 6.11: Ceiling bracket fixing

7 Service

Void Venu 208i loudspeakers should only be serviced by a fully-trained technician.



No user serviceable parts inside. Refer servicing to your dealer.

7.1 Return authorisation

Before returning your faulty product for repair, please remember to get an R.A.N. (Return Authorisation Number) from the Void dealer who supplied the system to you. Your dealer will handle the necessary paperwork and repair. Failure to go through this return authorisation procedure could delay the repair of your product.

Note that your dealer will need to see a copy of your sales receipt as proof of purchase so please have this to hand when applying for return authorisation.

7.2 Shipping and packing considerations

- When sending a Void Venu 208i loudspeaker to an authorised service centre, please write a detailed description of the fault and list any other equipment used in conjunction with the faulty product.
- Accessories will not be required. Do not send the instruction manual, cables or any other hardware unless your dealer asks you to.
- Pack your unit in the original factory packaging if possible. Include a note of the fault description with the product. Do not send it separately.
- Ensure safe transportation of your unit to the authorised service centre.

8 Appendix

Architectural Specifications

The loudspeaker shall be self-powered and comprising two high power 8" (203.2 mm) bandpass loaded low frequency (LF) transducers.

The enclosure shall be rectangular constructed from 15 mm multi-laminated birch plywood with a wraparound grille and a rotating badge; it shall have integral threaded inserts for the fitment of wall and ceiling mounting hardware; it shall be finished in a textured polyurethane with external dimensions of (H) 203 mm x (W) 600 mm x (D) 475 mm (8" x 23.6" x 18.7") and weigh 20 kg (44 lbs).

Performance specifications of a typical production unit shall be as follows: frequency response of 42 Hz – 120 Hz (± 3 dB from rated sensitivity); pressure sensitivity of 95 dB at one Watt at one metre.

The system shall be powered by its own internal 300 W dedicated power amplification module with DSP management and two 150 W at 4 Ω full range outputs.

The low frequency transducer shall be constructed on a cast aluminium frame with a treated paper cone, 50.8 mm (2") voice coil, wound with copper wire on a high-quality voice coil former for high power handling and long-term reliability.

The loudspeaker system shall be a Void Acoustics Venu 208i.

NORTH AMERICA

Void Acoustics North America

Call: +1 503 854 7134

Email: sales.usa@voidacoustics.com

HEAD OFFICE

Void Acoustics Research Ltd,
Unit 15, Dawkins Road Industrial Estate,
Poole, Dorset,
BH15 4JY
United Kingdom

Call: +44(0) 1202 666006

Email: info@voidacoustics.com



Hear. Feel. Connect.

voidacoustics.com